

UVO-CLEANER⁷

MODEL 256

INSTRUCTION MANUAL

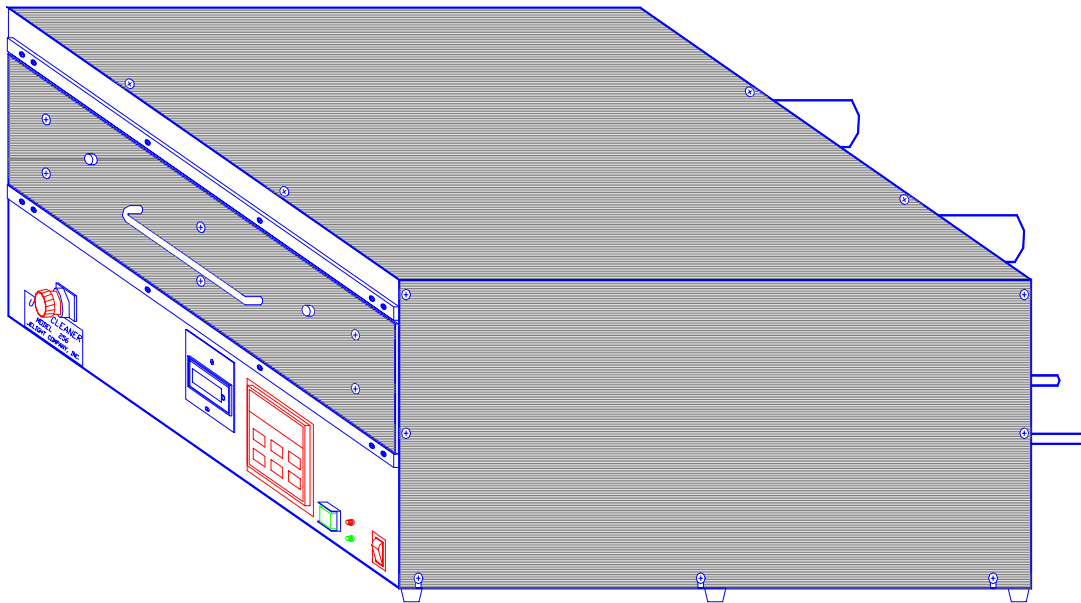

JELIGHT COMPANY, INC.

2 Mason

Irvine, CA 92618 U.S.A.

Tel: (949)380-8774 FAX:(949)768-9457

E-mail: sales@jelight.com

UVO-CLEANER⁷

MODEL 256

TABLE OF CONTENTS

Introduction	Page 3
Description	Page 4
Lamp Assembly	Page 5
Exhaust.	Page 6
Timer Operation.	Page 7
Valve Control Switch.	Page 8
Operation.	Page 9
Maintenance.	Page 10
Trouble Shooting	Page 11
Specifications	Page 12
Schematic.	Page 13

INTRODUCTION

The UVO-CLEANER⁷, Model 256 with 16" x 16" tray capacity produces near-atomically clean surfaces in less than one minute by utilizing the UV/Ozone cleaning method. This process effectively and thoroughly removes an assortment of organic contaminants from surfaces. These contaminants include human skin oils, silicone oils, solder flux, residues from wet cleaning processes or water residue, contamination absorbed during prolonged exposure to air, and many others.

For optimum results, the surfaces of the samples must be preplanned to remove contaminants such as dust and inorganic salts, which cannot be changed into volatile molecules by oxidation. To maximize the cleaning rate, samples should be placed as close to the UV source as possible.

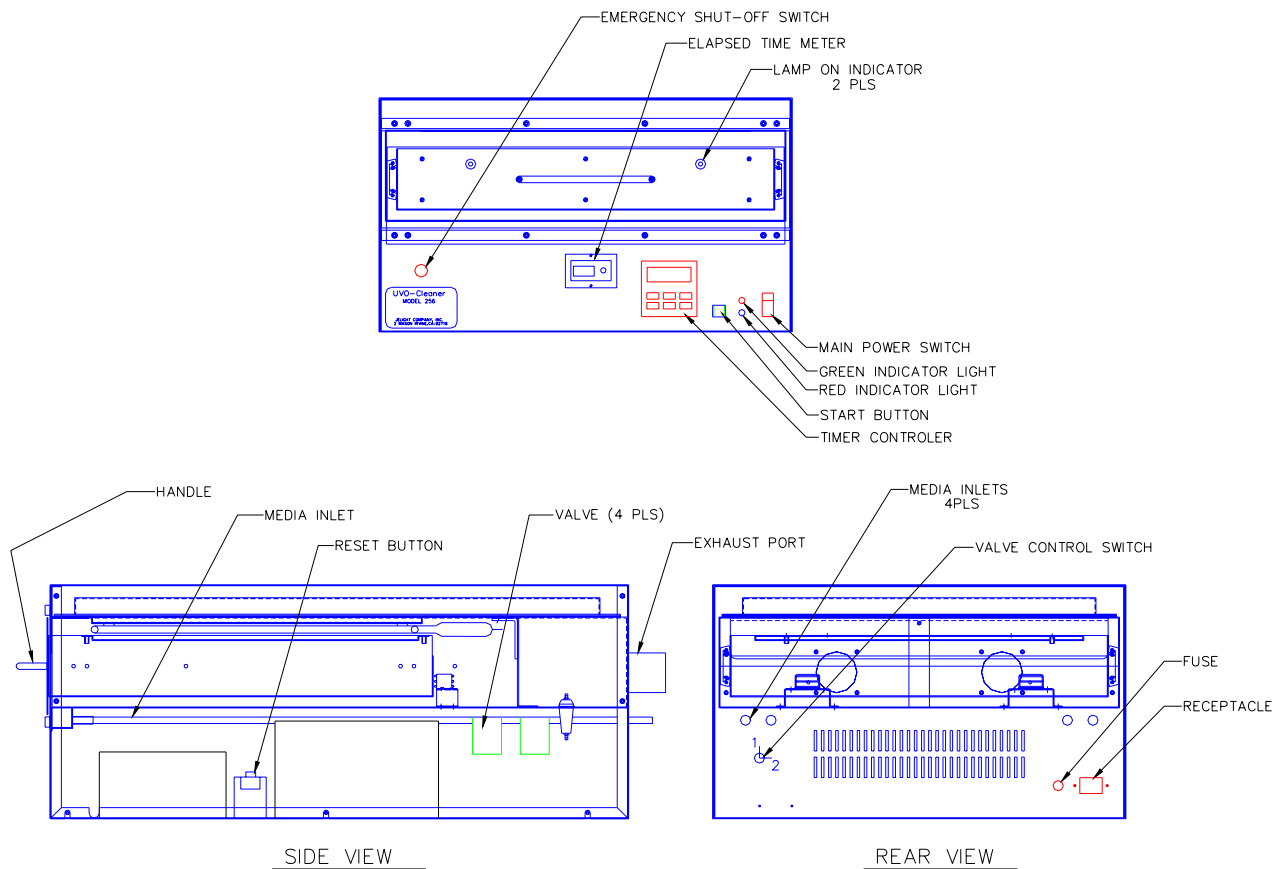

Figure 1

WARNING:

Potentially fatal voltages exist within this machine. Never remove the cover while the unit is plugged in to an electrical outlet. This unit produces ozone; thus, appropriate ventilation must be provided for the exhaust. Immediately deactivate the unit by pressing the emergency shut-off switch if ozone is detected. (See fig. 1)

The lamp in this unit emits harmful UV radiation; under no circumstances is exposure permissible. Qualified personnel must do servicing.

DESCRIPTION

The UVO-CLEANER⁷, Model 256 features a stainless steel cover, stainless steel drawer & base, and adjustable stainless steel cleaning tray. Four media inlet ports allow utilization of different gases simultaneously or in sequence.

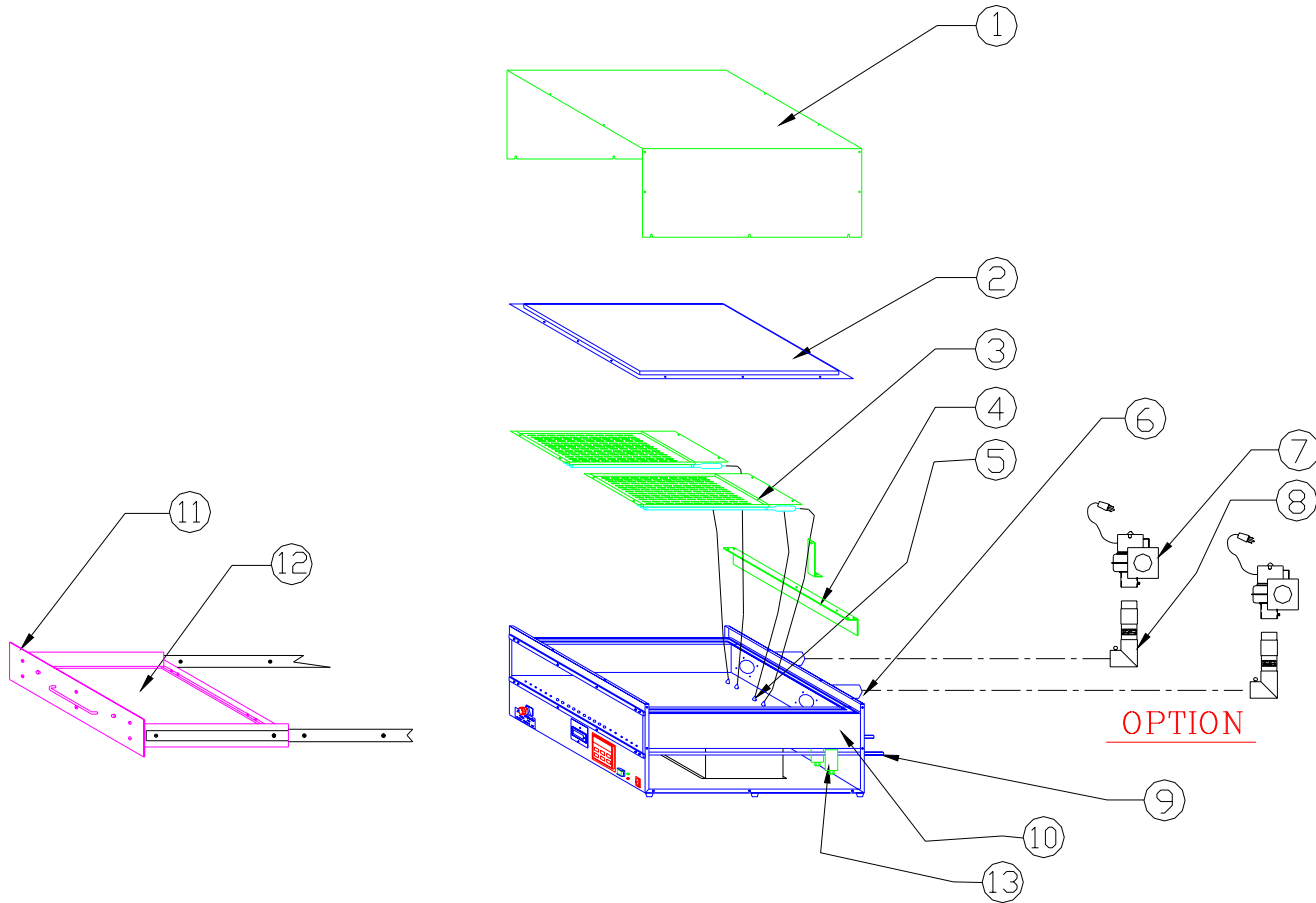

Figure 2

- | | | | | | |
|---|----------------------|----|-------------------------|----|--------------|
| 1 | Housing Cover | 6 | 2" Exhaust Port (2pls) | 11 | Drawer |
| 2 | Lamp Cover | 7 | Blower (Optional) | 12 | Tray |
| 3 | Lamp Assembly (2pls) | 8 | Ozone Killer (Optional) | 13 | Valve (4pls) |
| 4 | Lamp Support Bracket | 9 | Media Inlet (4pls) | | |
| 5 | Ceramic Feedthru | 10 | Shelf | | |

LAMP ASSEMBLY

Please see figure 2 to match corresponding reference numbers below.

To assemble lamps in the unit, remove all #8-32 screws from housing cover(1).

Remove lamp cover(2).

Carefully place the two lamp assemblies facing down unto the lamp support bracket(4). Secure lamp assemblies with the #8-32 x .30 long screws provided.

Connect the lamp wires to the ceramic feed-thru(5) located directly in front of each lamp assembly.

Place lamp cover(2) over lamp assembly and secure with the #8-32 x .30 long screws.

Press the reset button for the elapsed time meter. Refer to figure 1. This resets the meter to 0-00. The elapsed time meter keeps the time that the lamps have been in use.

While pushing the cover interlock switch, place the cover on the unit(1).

Secure the cover with the #8-32 screws.

EXHAUST

The Model 256 has two exhaust ports at the rear of the unit (see fig. 1). These ports may be connected:

- (1) Directly to an exhaust system capable of dissociating ozone,
- (2) to ozone killers (Model OKL200-4) and then to an exhaust system
- (3) to ozone killers and blowers, if no exhaust system is accessible. This assembly will allow exhausting safely into the operating environment.

Note: The flow rate of the input media should be equal to or less than that of the exhaust in order to maintain a positive flow of the media through the system. Using a greater flow rate of the input media will cause a backpressure in the unit forcing the exhaust gases to leak into the operating environment.

For options (1) and (2), the exhaust of the Model 256 must be attached to a suitable exhaust system capable of maintaining minus 0.50 to minus 2.0 inches of water static pressure while in operation. It is recommended that a flexible metal 2-inch duct be used to attach this unit to your exhaust system; a 2-inch PVC pipe may be substituted.

Once the unit has been fully assembled, it is important to test for leaks between the connections. If ozone is detected, stop the unit by pressing the emergency shut off switch and correct the source of the leakage.

For option (3), allow the blowers to function continuously, during and after cleaning cycles. To assemble, simply connect the ozone killers to the exhaust ports and mount the blowers at the other end of the ozone killers. Secure the blowers with the knob provided on their brackets.

TIMER OPERATION

The Model 256, utilizes a timer with dual timing cycles. The first timing cycle is used for the cleaning process. The second cycle is used for the exhaust of ozone in the unit's chamber.

Keypad Overview

The following paragraphs describe the function of the 6 front panel keypads.

Set : Pressing this key calls the prompted setpoint programming. Pressing this key the first time will call the SET1 prompt indicating the setpoint value with a flashing digit. The flashing digit is the one that can be changed using the ↑, ↓, and ← keys. Pressing the SET key again will scroll the SET2 prompt and its respective setpoint value. The time can be set as indicated previously in setting SET1. Pressing the SET key again returns the display to the actual time value.

← : This is the cursor key used to move the position of the flashing digit. The values of the flashing digit can be changed using the ↑ and ↓ keys.

ENT : This key enters any time changes into memory. When the ENT key is pressed, the display flashes once to indicate that the new time has been entered into memory.

RST : This key resets the timer to the first time cycle. This key should never be used when the unit is operating. **It is important to allow the unit to complete both timing cycles before opening the machine's drawer.**

The following outline shows the sequence for the front panel prompted programming routine for both the cleaning and exhaust cycle times.

Key Sequence	Display
Press SET key	SET1 prompt is displayed
Press SET key	Current cleaning cycle time is displayed with flashing digit indicating that the time can be changed.
Change time using ↑, ↓, and ← keys.	New cleaning cycle time displayed.
Press ENT key	Cleaning cycle time entered into memory.
Press SET key	SET2 prompt is displayed.
Press SET key	Current exhaust cycle time is displayed with flashing digit indicating that the time can be changed.
Change time using ↑, ↓, and ← keys.	New exhaust cycle time displayed.
Press ENT key	Exhaust cycle time entered into memory
Press SET key	Display shows cleaning cycle time. End of prompted set-up routine

INLET CONTROL VALVE

The Model 256 is equipped with four inlet ports in the rear of the unit, which allow different gas media to be used independently or simultaneously. The inlet ports are connected to internal electrical valves, which may be controlled by the valve control switch located in the rear of the unit (Refer to figure 1).

When preparing machine for use, remove all black inlet plugs.

There are two settings that the operator may choose to operate the machine. Setting 1, allows two gas media to be utilized independently. In the first cycle time, media inlets 1 and 4 are opened and media inlets 2 and 3 remain closed. In the second cycle time, media inlets 1 and 4 are closed and media inlets 2 and 3 are open.

When using setting 1, connect the oxygen to media inlets 1 and 4 and other media to 2 and 3. If you wish to use room air instead of an oxygen cylinder, leave media inlets 1 and 4 exposed.

Setting 2, is used if there is only one media employed. All media inlets will remain open for both cycle times. If room air is to be used, leave all media inlets exposed.

Utilizing media inlets to decrease exhaust time

The operator can decrease the exhaust time of the ozone from the unit's chamber, by applying a combined 1-2 pounds of pressure through the media inlets. Compressed air, oxygen or any inert gas may be used. For two pounds of pressure, the exhaust time is approximately two minutes. To set the exhaust cycle time see *Timer Operation*.

If no media cylinders are utilized, the exhaust cycle time should be no less than six minutes.

OPERATION

To operate the UVO-CLEANER⁷, Model 256, first install the lamp assembly. Refer to *Lamp Assembly*. Secondly, choose the exhaust method most suitable to your operating location. Refer to the section *Exhaust*.

Once the main power cord is plugged into an electrical outlet, the main power switch can be turned on. The main switch will light indicating power to the unit.

Remove the cover from the media inlets. Should you require media other than air, use proper connectors to attach to the media inlets. Test for potential leaks. For best results, the combined maximum flow rate through the inlets should not exceed 0.5 liter per minute.

Next, load the substrate onto the removable cleaning tray. The parts must be pre-cleaned since removing large amounts of contamination will take longer periods of time.

Adjust the side thumbscrews on the drawer to the appropriate settings for the desired height. The actual height of the tray varies according to the height of the product being cleaned. For optimum results, the surface of the parts being cleaned should be placed approximately 5 mm away from the bottom of the lamp.

Once the drawer is shut completely, the safety interlock switch engages. If either the drawer is opened or the cover removed, the safety interlock mechanisms automatically shut off the UV light source. Thus, accidental exposure to harmful UV radiation is prevented.

To set the cleaning time and exhaust time cycles, refer to the section *Timer Operation*. Cleaning times vary from applications to application. The operator should perform several trial runs to determine the appropriate cleaning time. For determining the exhaust time please refer to *Valve Control Switch*.

Set the valve control switch to the 1 or 2 positions as described in the section titled *Valve Control Switch*.

Once the cleaning and exhaust time cycles have been programmed into the timer, push the green start button to activate the timer. The red indicator light will illuminate acknowledging that the cleaning cycle has been initiated. **Never open the drawer when the red indicator light is on to avoid exposure to ozone.** The timer will indicate that it is in the cleaning cycle by a small dot on the lower left corner of the timer display.

When the cleaning cycle is complete, the UV light source will be extinguished and the timer will continue to the programmed exhaust cycle time. The timer will indicate that it is in the exhaust cycle by a small red dot on the lower right of the timer display. The red indicator light will remain on warning the operator that it is not safe to open the unit's drawer. When both cycles have been completed, the timer will sound an audible alarm. The green indicator will light indicating that it is safe to open the drawer. The drawer can then be opened the tray removed, and the parts unloaded.

Note: If ozone is detected, immediately deactivate the unit by pressing the emergency shut off switch. To reactivate the unit, turn the emergency control switch clockwise and allow both time cycles to continue. Lamps will remain off.

If the unit is interrupted during operation, allow both cycles to be completed before opening the unit's drawer. **Never open drawer when the red indicator light is on. Always wait for the green indicator light to illuminate before opening unit's drawer.**

MAINTENANCE

The maintenance of the UVO-CLEANER, Model 256 requires the user to remove and clean the lamp assembly once every 100 hours of operation.

Every 5,000 to 10,000 hours of operation, the lamp assembly must be removed and replaced.

To install a new lamp assembly, refer to *Lamp Assembly*

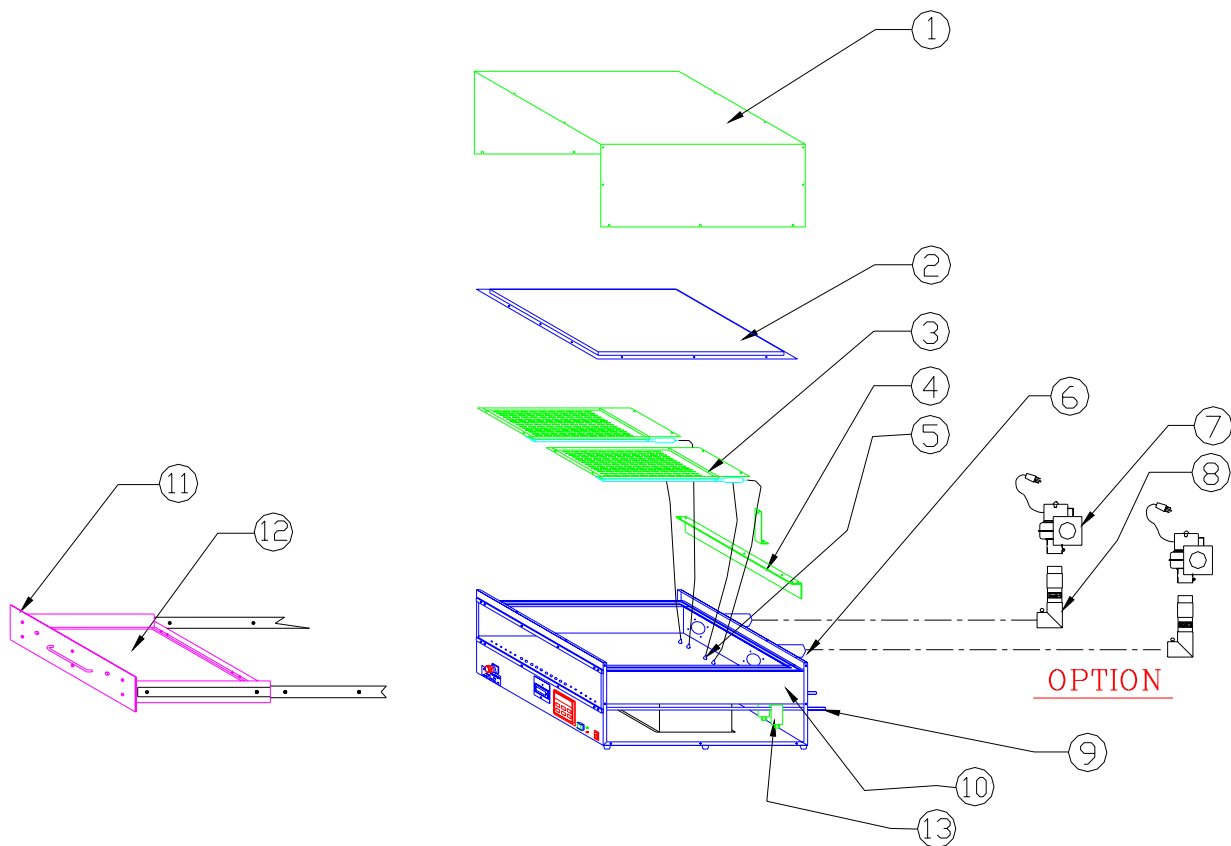

- | | | | | | |
|---|----------------------|----|-------------------------|----|--------------|
| 1 | Housing Cover | 6 | 2" Exhaust Port (2pls) | 11 | Drawer |
| 2 | Lamp Cover | 7 | Blower (Optional) | 12 | Tray |
| 3 | Lamp Assembly (2pls) | 8 | Ozone Killer (Optional) | 13 | Valve (4pls) |
| 4 | Lamp Support Bracket | 9 | Media Inlet (4pls) | | |
| 5 | Ceramic Feedthru | 10 | Shelf | | |

TROUBLE SHOOTING

SYMPTOM: Power To The Unit But Timer Does Not Function.

Check the power source.

Check the power receptacle.

Check the fuse.

Check the cover & drawer interlock mechanism.

SYMPTOM: UV Indicator Does Not Light.

Check power indicator lamp.

Replace the UV lamp assembly.

If this does not solve the problem, contact the factory.

SYMPTOM: Ozone Is Present Outside Of The Unit During Operation.

Check the exhaust connections.

Check the exhaust the unit is attached to.

SPECIFICATIONS

Size(Max)	20.50" W x 32.00" D x 12.00" H
Power Requirements	110 Volts, 60 Hz., 10 Amps
Lamp Type	Low Pressure Mercury Vapor Grid
Lamp Output	28,000 MicroWatts Per Sq. Cm @ 254nm (From 6mm Dist.)
Tray Size	16" X 16" Exposure Area

