

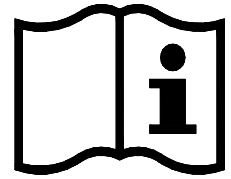

Jelight Company, Inc.
2 Mason, Irvine, CA 92618 U.S.A.
1-949-380-8774



OPERATING INSTRUCTIONS

JFC-412EX

FLOOR CURE SYSTEM



Rev C

EN

TABLE OF CONTENTS

Page	Title
4	INTRODUCTION
5	ICONS USED IN THIS MANUAL
 Warning Icons
6 General Advisory Icons
 Informative Icons
7	EQUIPMENT SAFETY LABELS
8	EQUIPMENT SERIAL NUMBERS
9	SAFETY GUIDE
 Basic Precautions
 Risk of Explosion
 Risk of Fire
10 Hazardous Voltage
 Grounding Instructions
 Hot Surface(s)
11 Pinch Point, Crush Hazard
 Ultraviolet (UV) Light
12 UV Protective Garments and Warning Sign
13 Ozone Inhalation Hazard
 What to do if the UV Lamp Breaks
14 Moving Instructions
15 Storage Instructions
 Vibration
 Sound Pressure Level
 Save These Instructions
16	CONTROLS AND CONNECTIONS
17 Control Console
18	OPERATING INSTRUCTIONS
 Connect Power Cords
 To Start the UV Lamp
19 Standby Mode
 To Switch the UV Lamp Off
20	TRAINING INSTRUCTIONS
 Planning
 Receiving the Floor Cure Machine
 Unpacking the Floor Cure Machine
21 Before Each Use
 Before Applying Coating
 Cure Width
22 Cure Start
 Cure Overlap
23 Curing Difficult Areas – Example
26 Curing Inclines
27	USER-MAINTENANCE INSTRUCTIONS
 Recommended Tools and Supplies
 Optional Tools
 Recommended Spare Parts
28 To Change the UV Lamp
29 Maintenance Schedule
 Preparation for Each Use
 Every 3 months

TABLE OF CONTENTS Continued

30	TROUBLESHOOTING
32	SPECIFICATIONS
33	LIMITED WARRANTY
35	WARRANTY REGISTRATION FORM
37	APPENDIX A: CONNECT JFC-412EX TO TWO 120V, 15A SOCKET OUTLETS
38	APPENDIX B: PACKAGING FOR SHIPMENT
39	APPENDIX C: CAUTION SIGN (copy as required)

INTRODUCTION

The JFC-412EX Floor Cure System is a portable Ultraviolet (UV) Light Irradiator and Power Supply for use in commercial applications. The Irradiator Module provides a significant UV light source for fast and efficient curing and is equipped with an automatic shutter system to prevent damage to floors and coatings when the system is stationary.

The Floor Cure System comes standard with a telescoping handle and the Control Panel angle is adjustable. A special wheel configuration enables sideways movement. The Floor Cure System is fitted with a series of safety features to protect the user and prevent damage to the system.

This manual contains instructions for the safe setup and operation of this Floor Cure System. Please read and follow this instruction manual carefully before use to maximize machine performance and to avoid the risk of safety hazards.



Fig. 1

ICONS USED IN THIS MANUAL

WARNING ICONS



WARNING! Severe equipment damage, serious injury or death may result



DANGER! Risk Of Explosion
WARNING! Risk Of Explosion



WARNING! Risk Of Fire



WARNING! Hazardous Voltage



WARNING! Hot Surface



WARNING! Ultraviolet Light



WARNING! Inhalation Hazard



WARNING! Poison



WARNING! Lifting Hazard



WARNING! Pinch Point, Crush Hazard

GENERAL ADVISORY ICONS



NOTE

General Advisories -
operational procedures, order of
operation, etc



Wear UV Face Shield



Wear Protective Clothing



Wear Protective Gloves



Wear Safety Boots



Wear Respirator



Do Not Place Electronic Waste
in the Trash



Do not Stack

INFORMATIVE ICONS



Operator's Manual;
Operating Instructions

EQUIPMENT SAFETY LABELS



JW-556

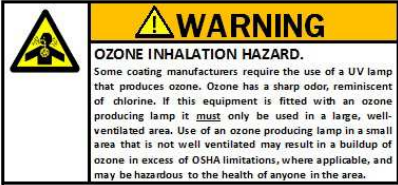

JW-713



EQ-1088

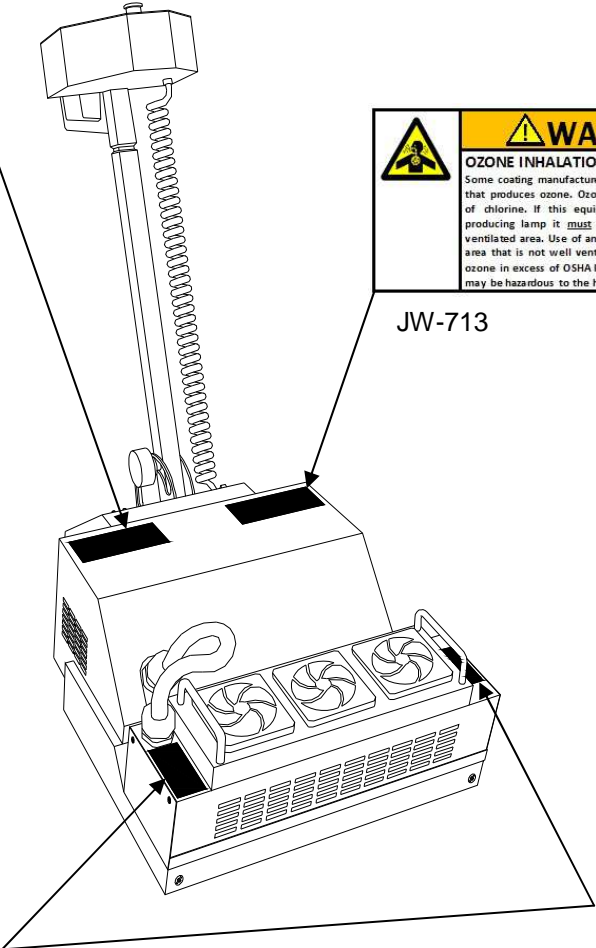

Fig. 2
 Equipment Safety Label Locations

EQUIPMENT SERIAL NUMBERS

Machine:

The equipment Serial Number is indicated at the lower rear of the machine. In the example shown in Fig. 3, the Serial Number is F000X.

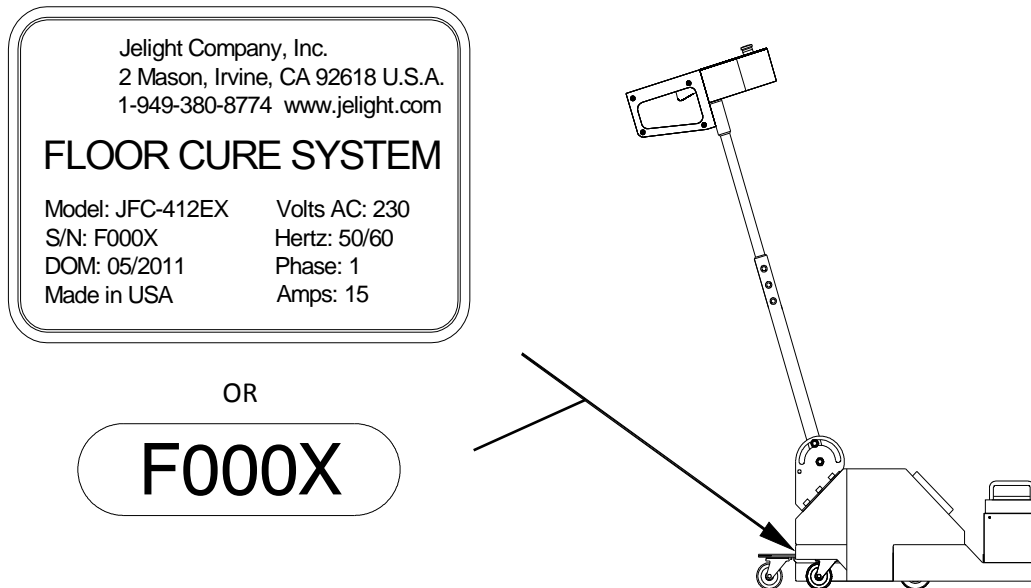

Fig. 3 Machine Serial Number

UV Lamp:

The UV Lamp has a four digit Part Number, preceded by the letters UVC. There is also a five digit Serial Number etched below the part number. In the example shown in Fig 4, the Part Number UVC-1658 and Serial Number is 12345.

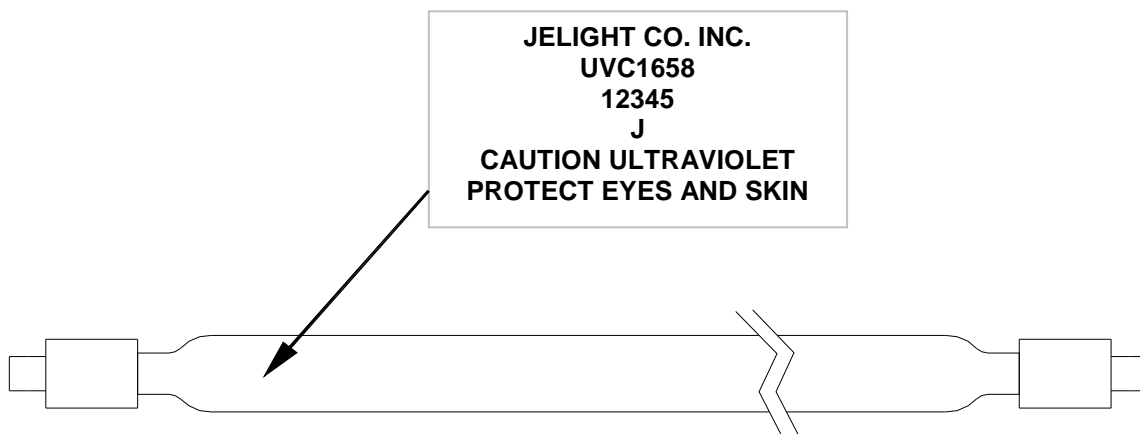

Fig. 4 UV Lamp Serial Number

SAFETY GUIDE



IMPORTANT SAFETY INSTRUCTIONS SAVE THESE INSTRUCTIONS

INSTRUCTIONS PERTAINING TO A RISK OF FIRE, ELECTRIC SHOCK, OR INJURY TO PERSONS

1. **WARNING! When using electric equipment, basic precautions should always be followed, including the following;**

- a. Read all the instructions before using the equipment.
- b. This equipment is to be used only by qualified and trained personnel. See the Training section in this manual.
- c. This equipment is not intended for use by persons (including children) with reduced physical, sensory or mental capabilities, or lack of experience and knowledge, unless they have been given supervision or instruction concerning use of the appliance by a person responsible for their safety.
- d. Know how to turn off the product. Be thoroughly familiar with the controls.
- e. Stay alert – watch what you are doing.
- f. Do not operate the product when fatigued or under the influence of alcohol or drugs.
- g. Do not operate equipment or enter the work area if nursing or pregnant.
- h. Do not operate if you suspect there is a problem with the equipment. Have the equipment checked by a qualified technician.
- i. Do not place the equipment on an unstable surface.
- j. Follow the maintenance instructions specified in the manual.
- k. Store these instructions in an area provided on the equipment.

2. **DANGER! Risk Of Explosion;**

- a. Do not use in paint spray booths or within 10 feet of paint spraying operations. Do not direct equipment at combustible materials.

WARNING! Risk Of Explosion;

- b. This equipment has internal arcing or sparking parts which should not be exposed to flammable vapor.

3. **WARNING! Risk Of Fire;**

- a. This equipment directs highly focused light to the ground. This can ignite UV curable coatings and cause significant damage to floor surfaces.
- b. Use only manufacturer approved supply cords. Incorrectly rated supply cords can pose a fire hazard.
- c. Do not block or cover any ventilation slots on the machine.
- d. Allow the machine at least 15 minutes to cool before lifting or packing the machine for transit.



4. **WARNING! Hazardous Voltage;**

This equipment and power cord operate at high voltages and current. Electric shock from any of these components can cause serious injury or death.

- a. This equipment is for dry use only and shall not be used or stored outdoors in wet conditions.
- b. Do not allow the power cord to rest on wet floors.
- c. Observe warnings and directions on all warning labels and instruction labels located outside and inside the equipment.
- d. Remove the plug on the Supply Cord from the socket-outlet before cleaning the equipment or performing maintenance.
- e. Do not use equipment with a damaged Supply Cord, loose wires or broken plugs, receptacles or socket-outlets.
- f. Do not attempt to repair a damaged Supply Cord. Contact the manufacturer for a replacement cord.
- g. Do not remove plug from socket-outlet while the machine is switched on or performing the cooling cycle.
- h. Do not operate with any cover open or removed.
- i. Do not bypass any safety interlock switches on this equipment.

GROUNDING INSTRUCTIONS

- a. This equipment must be grounded while in use to protect the operator from electric shock. If it should malfunction or breakdown, grounding provides a path of least resistance for electric current to reduce the risk of electric shock. This equipment is provided with a three conductor cord and a three-contact grounding type attachment plug to fit the proper grounding type receptacle. The green (or green and yellow) conductor in the cord is the grounding wire. Never connect this wire to other than the grounding pin of the attachment plug. The plug must be plugged into an appropriate socket-outlet that is properly installed and grounded in accordance with all local codes and ordinances.
- b. Improper connection of the equipment grounding conductor is able to result in a risk of electric shock. Check with a qualified electrician or serviceman if you are in doubt as to whether the equipment is properly grounded. Do not modify the plug provided with the equipment – if it will not fit the socket-outlet, have a proper socket-outlet installed by a qualified electrician.



5. **WARNING! Hot Surface(s);**

This machine will get hot in use and can cause severe damage to equipment and serious injury to persons.

- a. Always allow the machine to complete the cooling cycle after use.
- b. Allow the Irradiator Module, UV Lamp and surrounding surfaces to cool for at least 15 minutes before handling and wear protective gloves.
- c. Allow the Power Supply to cool for at least 15 minutes before removing the cover to perform maintenance. Electrical components will be hot.
- d. The floor beneath the machine and nearby work surfaces will be hot.
- e. Allow the machine at least 15 minutes to cool before lifting or packing the machine for transit.



6. **WARNING! Pinch Point, Crush Hazard;**

This equipment is heavy and contains moving parts that can cause severe injury to persons.

- a. Do not drive into persons in the work area.
- b. Do not touch the shutter mechanism underneath the Irradiator Module.
- c. Disconnect from electrical supply circuit before lifting equipment.
- d. Use caution when changing the position of the Control Handle.
- e. Use caution when installing the Irradiator Module.



7. **WARNING! Ultraviolet (UV) Light;**

Exposure to UV radiation is hazardous and can cause severe equipment damage, serious injury to skin, eyes and immune system or death.

- a. Place UV warning signs in prominent locations and cordon off work area with protective measures such as curtains or shutters. The work area is typically the room in which UV curing takes place – see Fig. 5.
- b. Do not permit animals into the work area.
- c. Mask nearby surfaces and equipment to prevent damage by UV light.
- d. This equipment requires one qualified operator and may necessitate one assistant to manage the power cord. No other persons should be permitted into the work area while the equipment is in use.
- e. All persons in the work area must be made aware of the danger zone – see Fig. 5.
- f. Do not start the machine unless all persons in the danger zone are wearing UV protective face shields and garments providing full skin coverage – see Fig. 6.
- g. Do not start the machine unless all persons in the work area are wearing UV protective goggles and full length garments.
- h. Ensure that persons without UV protective eyewear and garments stay outside the work area.
- i. Do not look directly at UV light.
- j. When the equipment is in Standby mode, some UV light is still visible inside the Irradiator Module and under the machine. Do not remove UV protective Face Shield or garments or allow unprotected individuals into the work area while the machine is on.

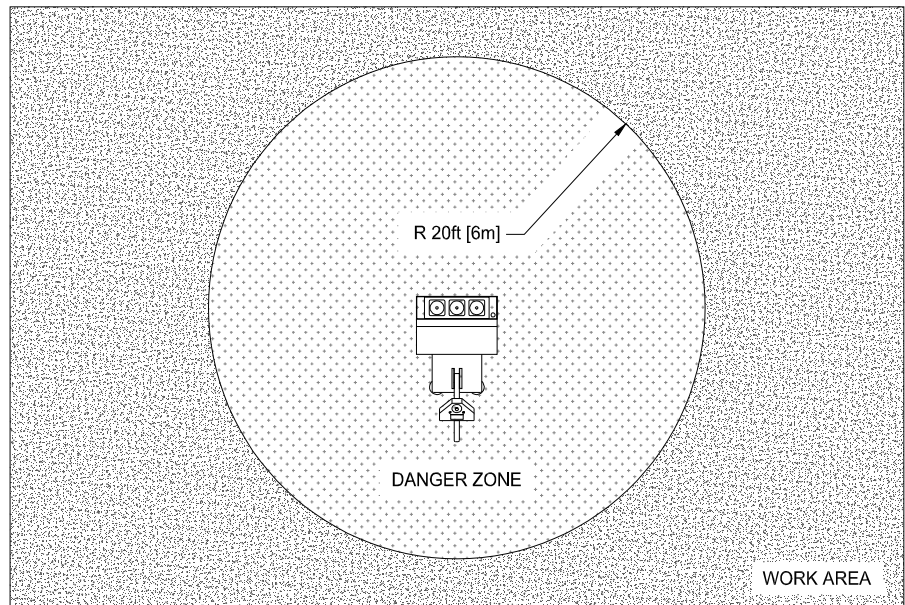

Fig. 5 Work Area and Danger Zone



Fig. 6
UV Protective Garments and Warning Sign



8. **WARNING! Ozone Inhalation Hazard**

Some coating manufacturers require the use of a UV lamp that produces ozone. Ozone has a sharp odor, reminiscent of chlorine. If this equipment is fitted with an ozone producing lamp it must only be used in a large, well-ventilated area. Use of an ozone producing lamp in a small area that is not well ventilated may result in a buildup of ozone in excess of OSHA limitations, where applicable, and may be hazardous to the health of anyone in the area.



9. **WHAT TO DO IF THE UV LAMP BREAKS**

WARNING! Inhalation Hazard;

WARNING! Poison;

WARNING! Hot Surface(s);

The UV Lamp used in this curing system contains mercury, a substance known to be hazardous to health and the environment. Always handle UV Lamps with care and wear gloves.



It may be necessary to contact your local municipality for information regarding the cleanup of mercury spills; it may not be legal to perform this task yourself. The following guidelines are for instances where cleanup can be performed by the operator. Suggested provisions are indicated in the User Maintenance, Recommended Tools and Supplies, Clean-Up Kit section in this instruction manual.



9a. **When indoors; before clean-up, air out the room**

- i. Evacuate the room, avoiding the breakage area as far as possible on the way out.
- ii. Open a window or door and vent the room to the out of doors for 15 minutes or more after evacuation.
- iii. Shut off central forced-air heating/air conditioning or any other internal air circulation system.
- iv. Wear chemically protective gloves, clothing and footwear. Use of a respirator is recommended.



9b. **Clean-up steps for hard surfaces**

- i. Do not use a vacuum or broom to clean up a broken UV Lamp.
- ii. Open a Newspaper and place 5 sheets on the floor next to the contaminated area.
- iii. Using a piece of cardboard approximately 6 inches [150mm] square to carefully scoop glass pieces and powder into a Dustpan. Place the broken pieces in the center of the Newspaper.
- iv. Carefully fold the corners of the Newspaper to the center to encapsulate all glass and powder fragments. Use Sticky Tape to fasten the corners and open edges of the Newspaper. Place Newspaper into the Biohazard Bag.
- v. Place the cardboard into the Biohazard Bag.
- vi. Use sticky tape to pick up any remaining small glass fragments and powder. Place dirty Sticky Tape into the Biohazard Bag.
- vii. Wipe the Dustpan and the floor area clean with damp Paper Towels. Place used Paper Towels into the Biohazard Bag.



9c. **Clean-up steps for absorbent surfaces**

- i. If a spill occurs on an absorbent surface such as carpet, cut and remove the contaminated portion and place in into the Biohazard Bag.

9d. Clean-up steps for the Irradiator Module

- i. Switch the equipment off. Remove the plug on the Supply Cord from the socket-outlet.
- ii. Equipment may be hot. Allow at least 15 minutes before handling Irradiator Module or UV Lamp.
- iii. Open a Newspaper and place 5 sheets on the floor next to the Irradiator Module.
- iv. Refer to User-Maintenance Instructions, To Change a UV Lamp section in this manual. At arms length, remove the Irradiator. Do not inhale any mercury vapor that may be present.
- v. Place glass pieces in the center of the Newspaper.
- vi. Remove the UV Lamp Metal End Caps from the Retaining Brackets and place in the center of the Newspaper.
- vii. Carefully fold the corners of the Newspaper to the center to encapsulate all glass and powder fragments. Use Sticky Tape to fasten the corners and open edges of the Newspaper. Place Newspaper into the Biohazard Bag.
- viii. Use Sticky Tape to remove any remaining small glass fragments and powder from the Irradiator and the Shutter. Place dirty Sticky Tape into the Biohazard Bag.
- ix. Wipe Irradiator and Cover clean with damp Paper Towels. Place used Paper Towels into the Biohazard Bag.



9e. Disposal of clean-up materials

- i. Seal the top of the Biohazard Bag with Sticky Tape.
- ii. If the Biohazard Bag is torn, reseal the broken area with Sticky Tape and place into a second Biohazard Bag.
- iii. Immediately place all clean-up materials outdoors in a protected area.
- iv. Check with your local or state government about disposal requirements in your specific area. Some states do not allow trash disposal. Instead, they require that broken and unbroken mercury-containing UV Lamps be taken to a local recycling center.
- v. Thoroughly wash your hands with soap after disposing of the Biohazard Bags containing clean-up materials.



10. MOVING INSTRUCTIONS

WARNING! Lifting Hazard; **WARNING! Hot Surface(s);**

This equipment is heavy; refer to the Specifications section in this manual. Inappropriate handling may result in back injury and/or damage to the machine.

- a. Wear protective gloves.
- b. Wear safety boots.
- c. Remove the plug on the Supply Cord from the socket-outlet before moving.
- d. UV Lamp and housing may be hot. Always allow the Irradiator Module to cool for 15 minutes before lifting.
- e. Lock the telescoping control panel tube before lifting.
- f. Always secure the equipment with tie down straps during transportation.

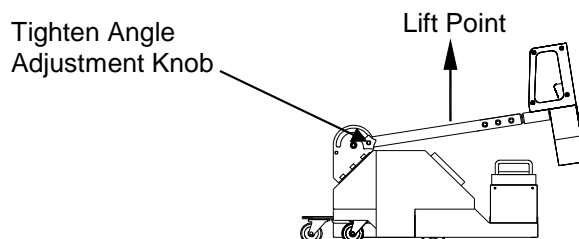

Fig. 7
Lift Point



11. STORAGE INSTRUCTIONS

- a. Refer to the Specifications section in this manual for recommended storage temperature and humidity ranges.
- b. Do not place into storage until equipment has fully cooled. Allow at least 15 minutes of cooling time before covering.
- c. Cover equipment to prevent dust from entering ventilation slots and holes.
- d. Do not stack equipment; keep on a level surface and do not store other equipment or coatings on top of the machine.
- e. Do not store outdoors.
- f. Do not allow equipment to get wet.
- g. Keep equipment away from chemicals.
- h. Store additional UV Lamps in the protective packaging provided.

12. VIBRATION

The vibration transmittance value of this equipment will differ with floor smoothness and speed of use. This equipment is not a significant source of vibration alone.

13. SOUND PRESSURE LEVEL

This audible output of this equipment is less than 85dB. Ear protection is not necessary.

14. SAVE THESE INSTRUCTIONS

Store these Operating Instructions with the equipment.

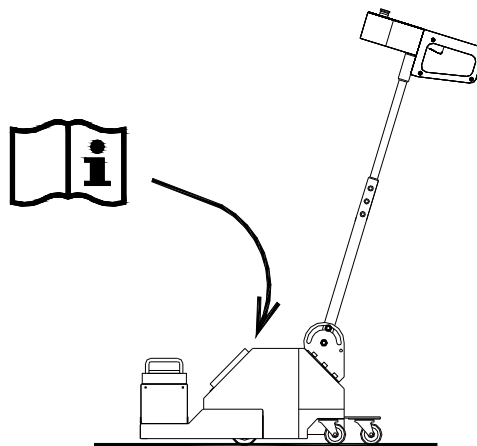

Fig. 8 Store Operating Instructions with Equipment

CONTROLS & CONNECTIONS

Control Panel	Contains control switches for UV Lamp, speed display and Emergency Stop Button.
Telescoping Handle	Provides three height adjustments and a lock for storage and shipment.
Power On/Off Switch	Push to switch the Floor Cure System on or off. This switch contains a Circuit Breaker. If the Circuit Breaker opens or if the Emergency Stop Button is activated, the machine will be disabled. To reset, push the Power On/Off switch back to the on position.
Quick Release Pin	Remove Pin to fold Control Handle forward or tilt back.
UV Lamp Housing	Remove for UV Lamp access.
Irradiator Fans	These fans provide cooling for the UV Lamp and components. The fans will start when the UV Lamp is switched on. When the UV Lamp is switched off the fans will continue to cool the Irradiator. Do not cover or block fan filters.
Thermal Switch Indicator	The indicator will illuminate blue if the Thermal Switch detects an over heat condition and switches the UV Lamp off.
Exhaust Vents	Do not cover or block vents at the front or rear of the Irradiator.
Irradiator Cover Screws	Remove two screws on each end of the Irradiator to remove UV Lamp Housing
Irradiator Removal Handles	Use to remove UV Lamp Housing

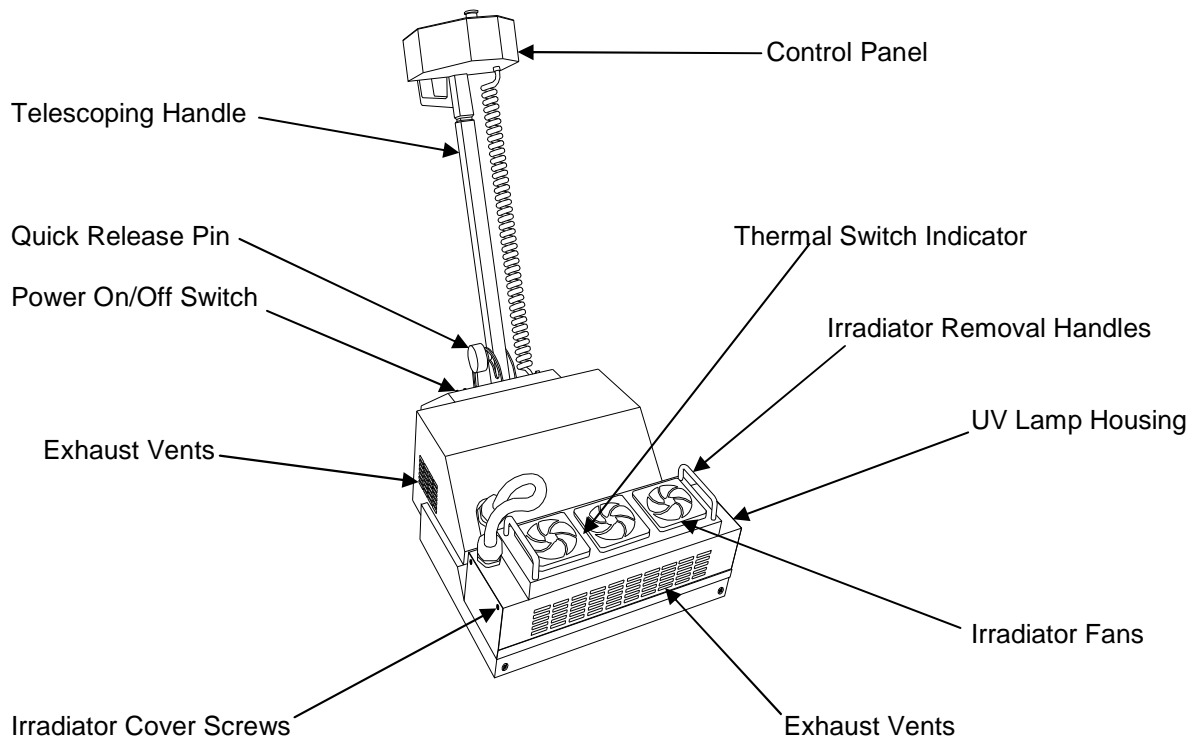

Fig. 9 Irradiator Module

CONTROL CONSOLE

Power Indicator	This (white) indicator will turn on whenever mains power is present.
Ready Indicator	This (green) indicator will turn on when the UV Lamp is ready for use.
Emergency Stop	To operate, push this button down to shut the machine off. To reset, twist the button clockwise and lift.
Speed Display	The display lights up when the main power cord is connected, indicating power is on. Press the 'SEL' (select) button to toggle between the Rate and Distance Counter modes. The Rate mode is indicated by the letter 'R' on the left side of the screen and the speed is displayed in feet per minute or meters per minute, depending upon region. The Distance Counter mode counts the total number of feet traveled (accumulative in either direction) by the unit since the last reset. To reset the Distance Counter, press the 'RST' button.
Lamp Switch	Push up to start and down to stop the UV Lamp.
Trigger	Pull Trigger upwards to open shutter and enable the UV Lamp to operate at the chosen power level.

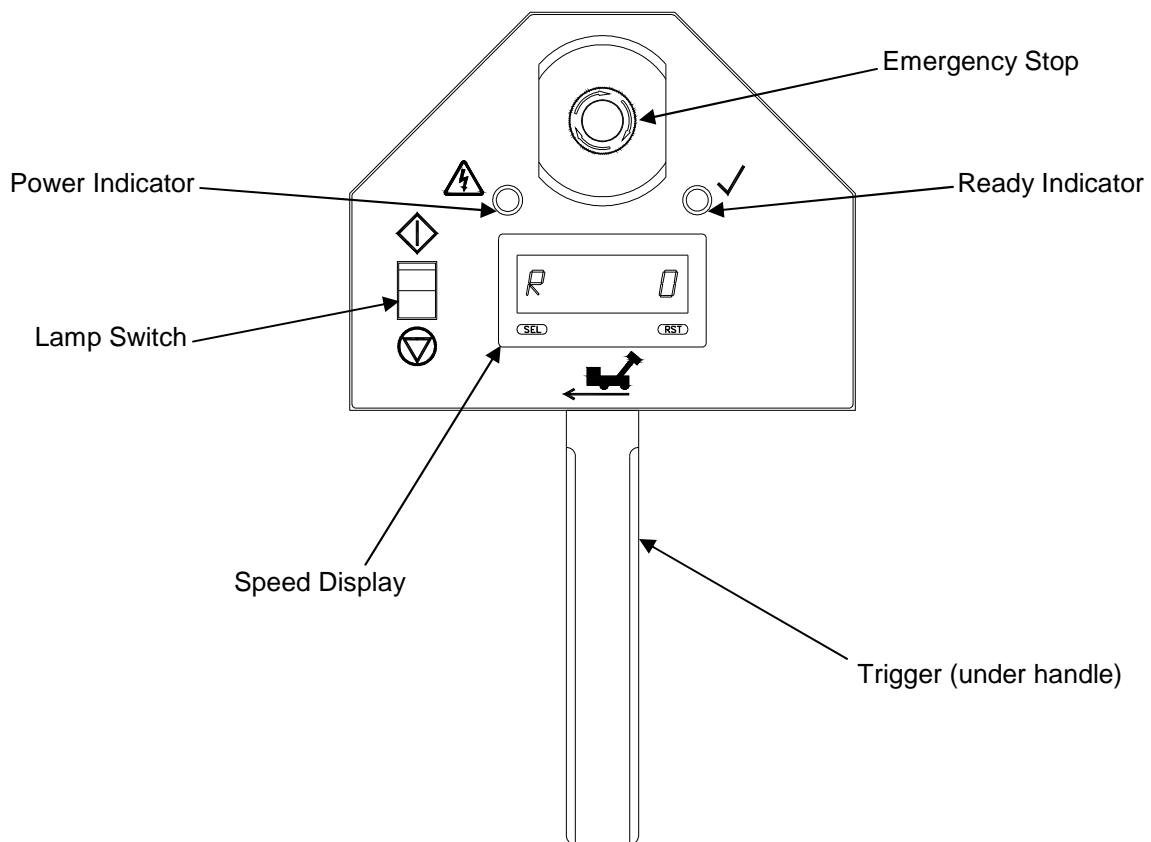

Fig. 10 Irradiator Module Control Panel

OPERATING INSTRUCTIONS



CONNECT POWER CORD

- Connect the plug on the Supply Cord to a socket-outlet.

WARNING! Severe Equipment Damage, Serious Injury Or Death May Result;

In Case of Emergency, push the Emergency Stop Button down on the Control Panel. Unplug the Power Supply. To reset the Emergency Stop Button, twist the button clockwise and lift.

WARNING! Severe Equipment Damage, Serious Injury Or Death May Result;

When the UV Lamp is on and the Trigger under the Control Panel Handle is pulled upwards, the shutter will open allowing the UV Lamp to emit high energy towards the floor. This can result in extremely high floor temperatures and potential for fire. Damage to floor surfaces, coatings and equipment may result. Ensure the machine is in motion whenever the Trigger is operated.

TO START THE UV LAMP

- All persons in the work area must wear UV protective garments and Face Shields before starting the UV Lamp.
- Do not operate the Trigger under the Control Panel Handle at this time.
- Ensure the Emergency Stop Button is in the reset (up) position.
- Move the Power On/Off switch to the on position. The white Power Indicator and the Speed Display on the Control Panel will illuminate. If switch does not latch on, twist the Emergency Stop Button clockwise to reset. If the white Power Indicator and Speed Display still do not illuminate, refer to the Troubleshooting section in this manual.
- On the Control Panel, move the Lamp Switch to the On position. The UV Lamp inside the Irradiator Module will light. If the UV Lamp does not light after 3 minutes, refer to the Troubleshooting section in this instruction manual.
- On the Control Panel, observe the green Ready Indicator. When the green Ready Indicator illuminates the Floor Cure Machine is ready for use. At this time, the system is in Standby Mode with the shutter closed.
- Position the machine in front of the area to be cured. Whenever possible, provide a short run-up to the cure area.
- Operate the Trigger underneath the Control Panel Handle to open the shutter and start curing. The machine must be kept in motion whenever the shutter is open.
- The machine can be steered with the Control Panel Handle.



WARNING! Severe Equipment Damage, Serious Injury Or Death May Result;

In Standby Mode the UV Lamp will continue to emit high energy towards the floor, even when the shutter is closed. This can result in extremely high floor temperatures and potential for fire. Damage to floor surfaces, coatings and equipment may result if the machine is left idle.



WARNING! Severe Equipment Damage Or Serious Injury May Result;

When the Floor Cure Machine is in Standby Mode, strong UV light may still be visible inside the Irradiator Module. Do not remove Face Shield, protective clothing or allow any unprotected persons or animals into the work area. Refer to the Safety section in this manual for further details.

STANDBY MODE

- Release the Trigger at any time to place Floor Cure Machine in Standby Mode.
- If Standby Mode duration is likely to exceed 10 minutes, move the Lamp Switch to the stop (down) position. The UV Lamp will cool down and can be restarted after the 5 minute cooling cycle completes.

TO SWITCH THE UV LAMP OFF

- When the curing task is complete, or if Standby Mode is likely to exceed 10 minutes, move the Lamp Switch to the stop (down) position.
- **Important: Allow the Cooling Fans on the Irradiator to operate for about 5 minutes before moving the Power On/Off Switch to the off position.**
- Disconnect the Supply Cord.

TRAINING INSTRUCTIONS



The following Training Instructions are intended to provide general guidelines for the successful use of this floor cure equipment.

The Floor Coating Supervisor is responsible for the safety and training of all persons in the work area. All personnel operating the machine must read and understand the safety and operating instructions before using the equipment. Regular equipment maintenance and performance awareness are essential to successful UV Coating applications.

Commercial Floor Curing will typically involve more than one piece of UV Curing equipment. A large curing machine will typically be required for wide open areas and a smaller UV curing machine or handheld unit will normally be used for intricate areas such as edges, corners, closets and stairways.

PLANNING

Familiarize yourself with the unique requirements of each work area. This will ensure a safe and efficient coating application.

- Facility considerations including but not limited to:
 - Equipment access
 - Power availability; sufficient voltage and current
 - Supply Cord length requirements
 - Work permits and disposal restrictions
- Safety considerations including but not limited to:
 - Protective clothing, footwear and eyewear
 - Warning signs and cordoning off the work area
 - Environmental hazards such as the presence of flammable materials
- Environmental requirements such as humidity level
- Surface preparation requirements
- Consult your UV coating supplier for the correct application procedure for your coating type. Many coating manufacturers offer training courses for contractors. Be aware of the requirements for each coating:
 - Application method
 - Application thickness
 - Cure speed
 - Number of coats
 - Repair and refinishing
- Plan the curing route



RECEIVING THE FLOOR CURE MACHINE

Always inspect the shipping crate and equipment for signs of damage. If serious damage is evident, document it and contact shipping company to file a claim.

UNPACKING THE FLOOR CURE MACHINE

- Keep crate and packaging materials.
- Follow the Moving Instructions located in the Safety section in this manual.
- Keep these Operating Instructions in the manual holder provided with the equipment.



BEFORE EACH USE

- Follow the maintenance instructions specified in this manual to ensure equipment is safe and clean.
- Check the Irradiator Module to make sure a UV Lamp is installed and is in good condition. If not, follow the removal and installation procedure in the How to Change a UV Lamp section in this manual.
- Uncoil all power cables before use.



BEFORE APPLYING COATING

- Check machine operation before applying coating.
 - Start the machine
 - Check shutter operation
 - Check the UV Lamp reaches the desired power level when the shutter opens
 - Check drive system operation

CURE WIDTH

The JFC-412EX has a 12 inch [30cm] Cure Width - see Fig. 11. The cure width may be wider, depending upon coating type and thickness.

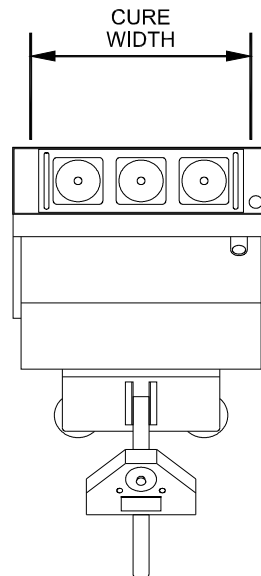

Fig. 11 Cure Width

CURE START

Whenever possible, provide a short run-up to the cure area. This fully enables the shutter to open and the UV Lamp to reach full power.

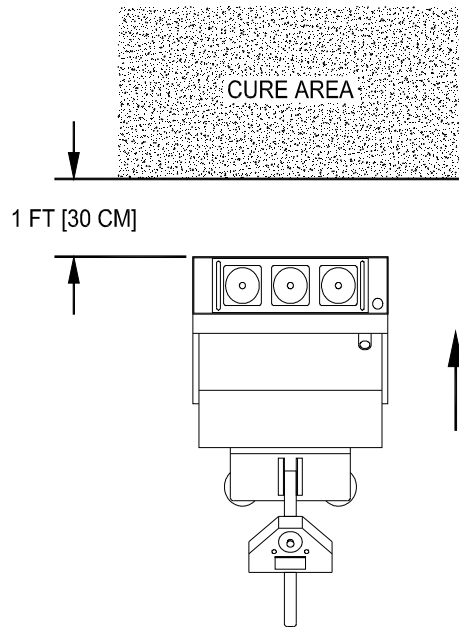

Fig. 12 Cure Start Position

CURE OVERLAP

Always overlap the cured area by approximately 1 inch [2.5cm] to ensure a consistent cure.

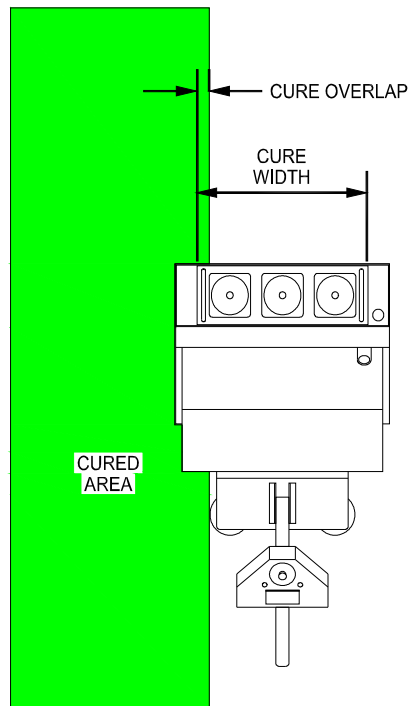
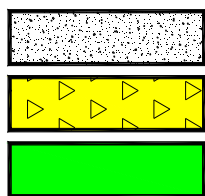
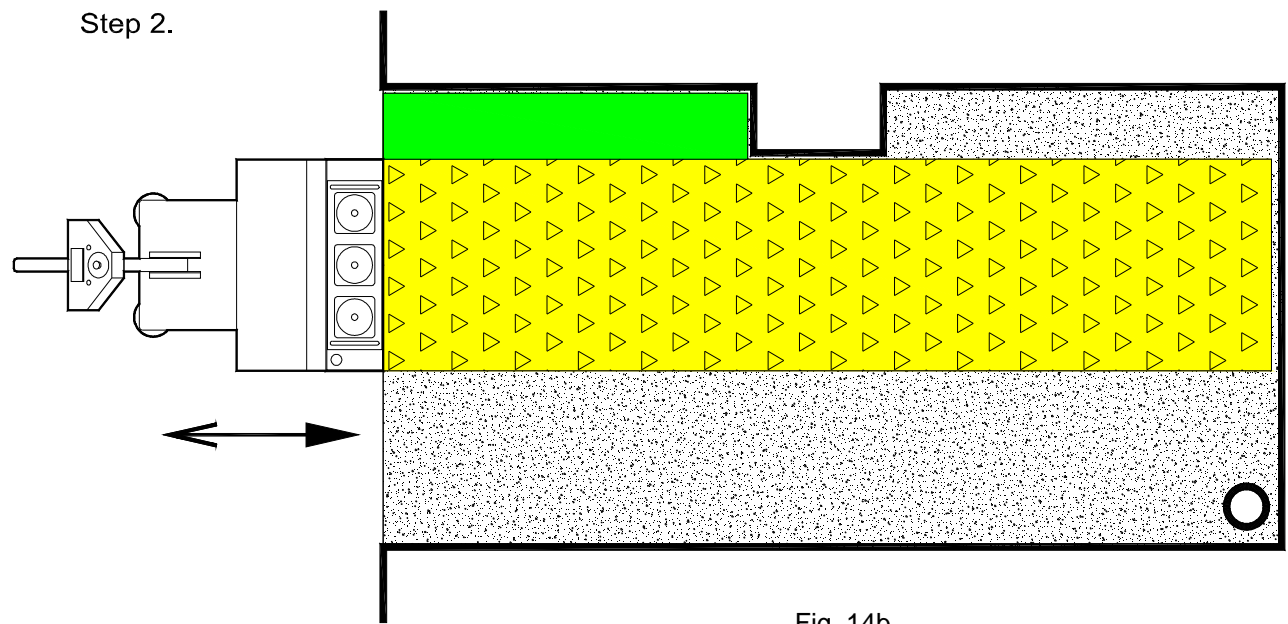
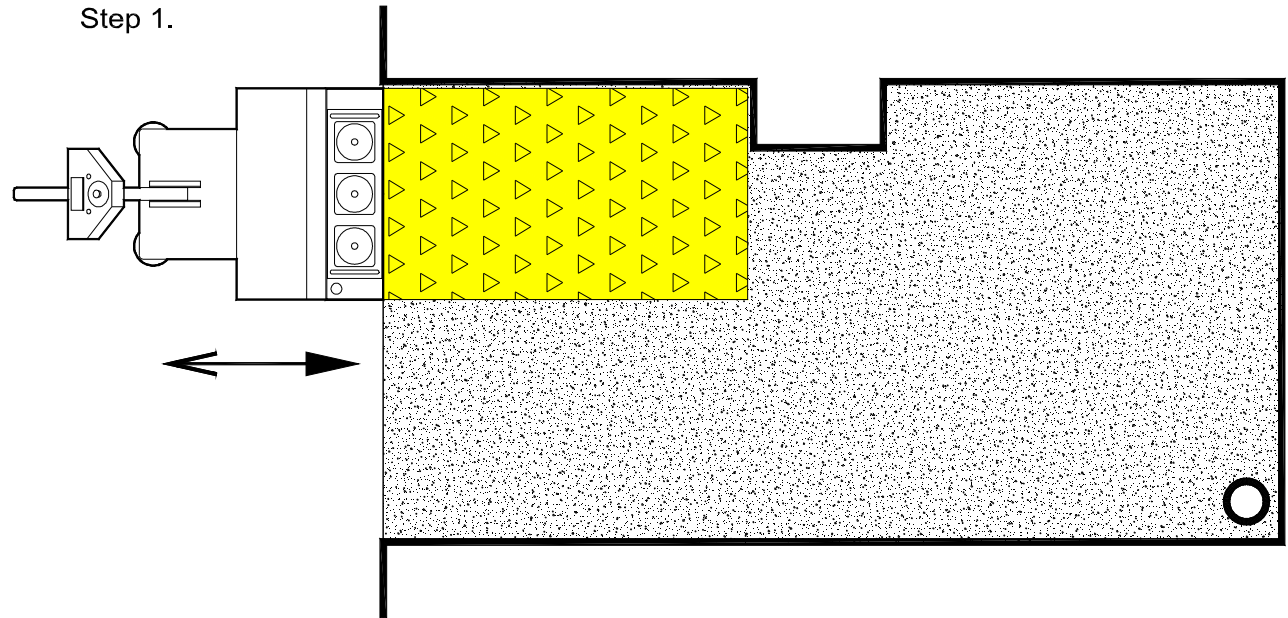

Fig. 13 Cure Overlap

CURING DIFFICULT AREAS – EXAMPLE



UNCURED AREA

MACHINE PATH

CURED AREA



FORWARD MOVEMENT



BACKWARD MOVEMENT

Step 3.

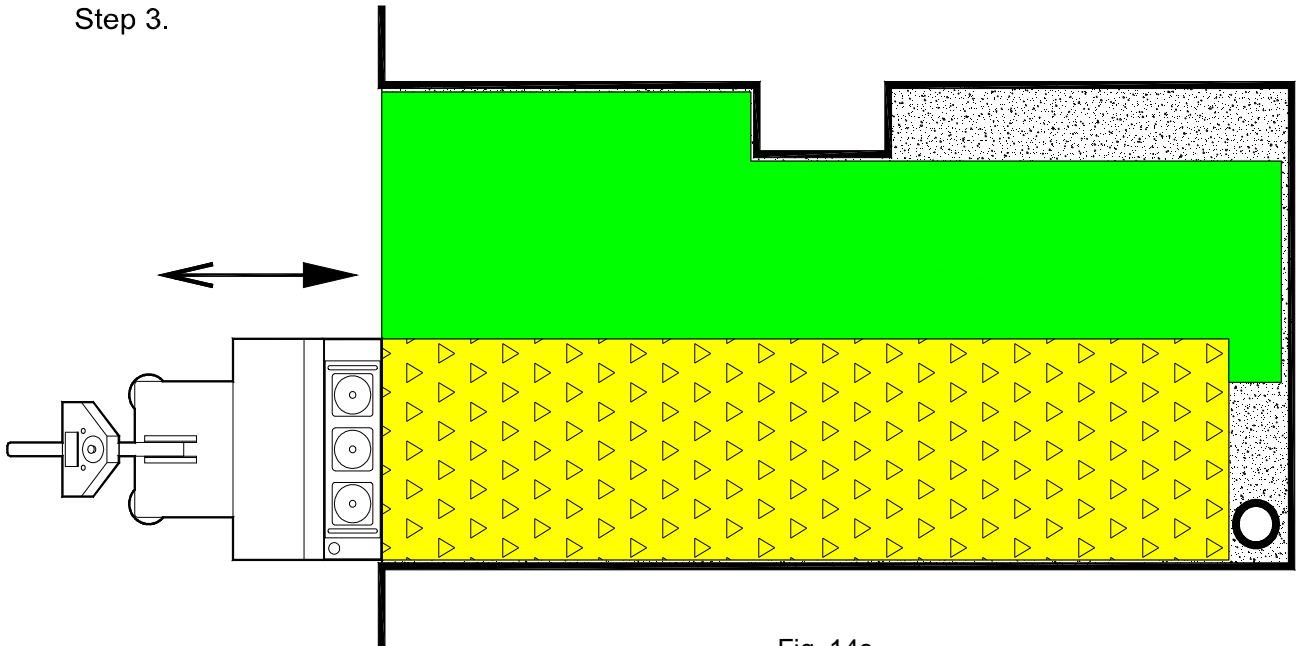

Fig. 14c

Step 4.

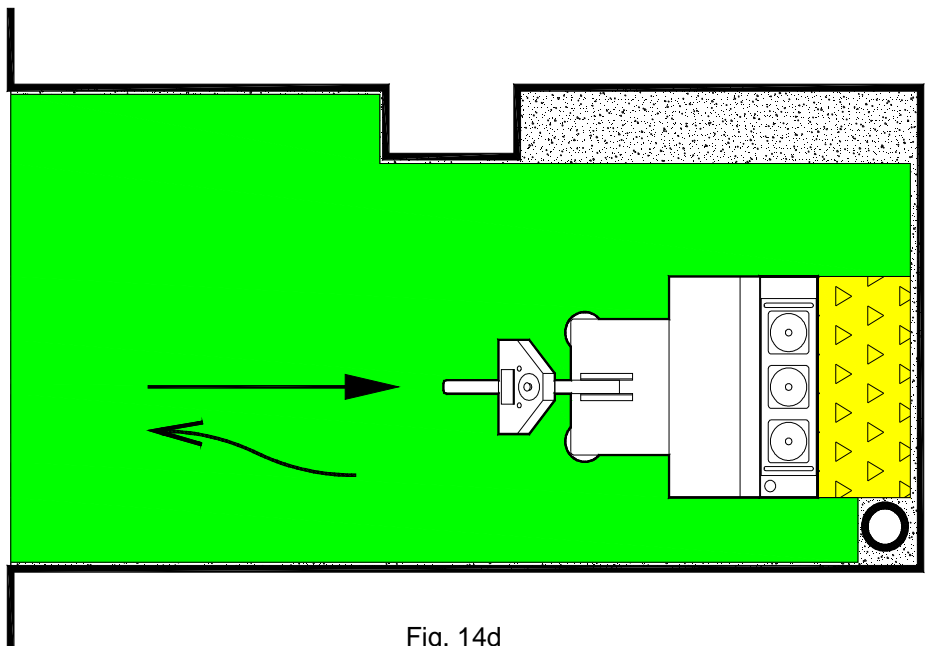
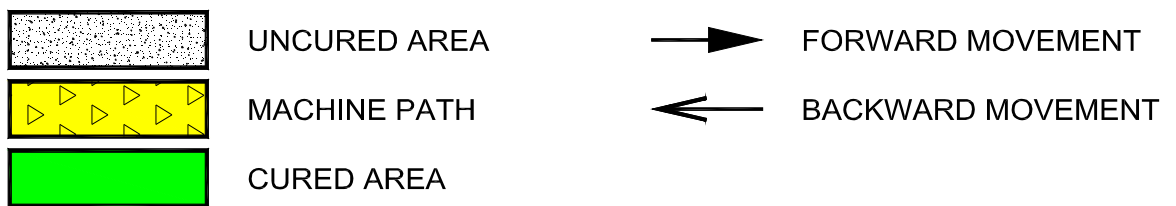

Fig. 14d



Step 5.

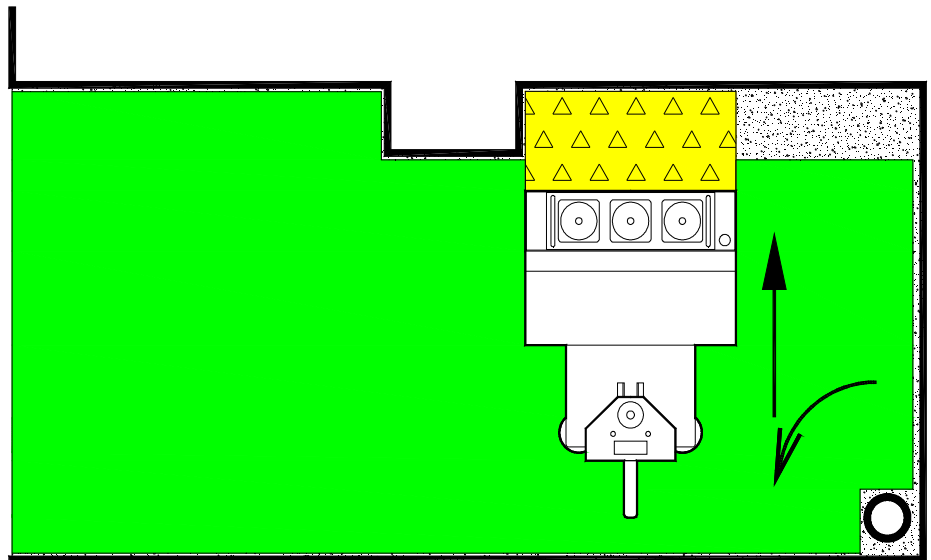

Fig. 14e

Step 6.

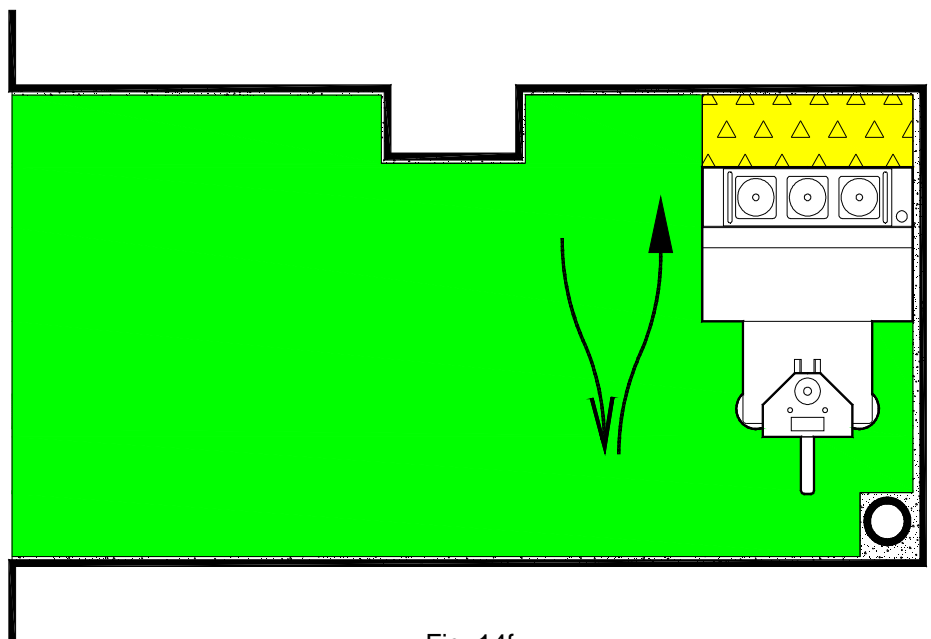
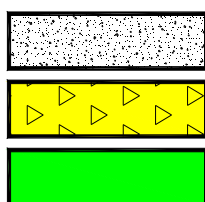

Fig. 14f



UNCURED AREA

MACHINE PATH

CURED AREA



FORWARD MOVEMENT



BACKWARD MOVEMENT

CURING INCLINES

Cure to the edge of each flat surface and do not allow the machine to ground out; damage to coatings and equipment may occur. To negotiate transitions onto steep inclines, tilt the machine backwards onto the rear casters.

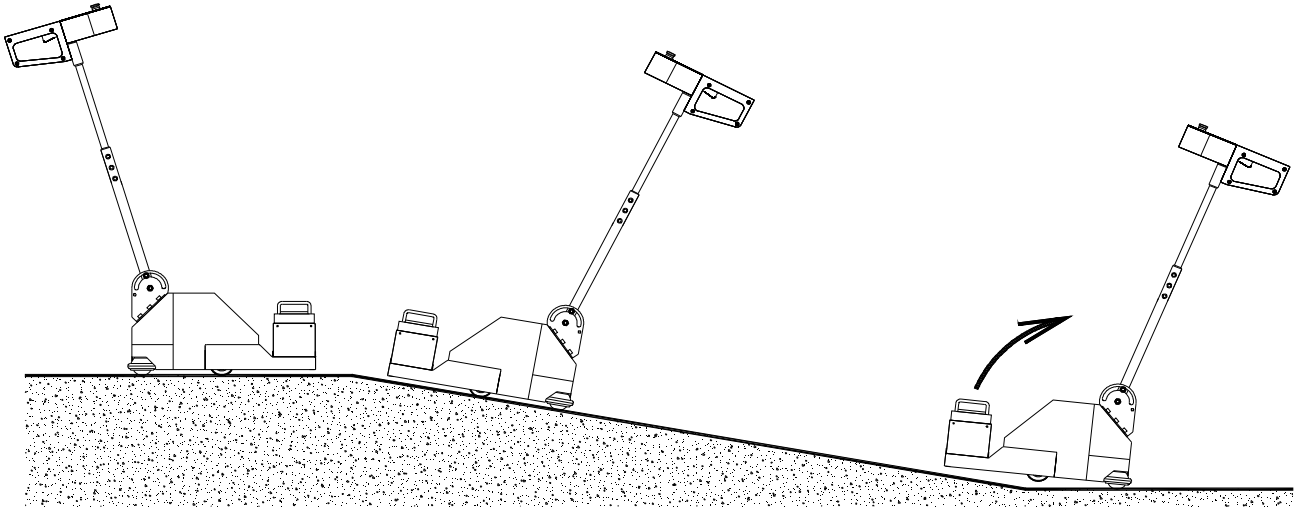

Fig. 15 Curing Inclines

USER-MAINTENANCE INSTRUCTIONS

RECOMMENDED TOOLS AND SUPPLIES

- Screwdriver set comprising of Phillips and Flat Blade tips. The set must include:
 - Phillips screwdriver with tip size no. 2
- Inch size Hex L-Key (Allen Key) set: 5/64 thru 3/16 inch sizes. The set must include:
 - 7/64 AF (.109 inches across the flats)
- Deionized (DI) Water
- Clean-Up kit for a broken UV Lamp;
 - Paper Towels
 - Cotton Cloths
 - Newspaper
 - Heavy duty Rubber Gloves
 - Biohazard Bags at least 20 inches [60cm] high
 - Heavy duty Sticky Tape approximately 2 inches [50mm] wide
 - Dustpan (brush is not required)
 - Cardboard pieces approximately 6 inches [150mm] square

OPTIONAL TOOLS

- Adjustable Wrench: 13/16 inch [20mm] max jaw size
- Pliers; Long Nose
- Multi-meter

RECOMMENDED SPARE PARTS

Contact your distributor or manufacturer for spare parts

- UV Lamp, part number UVC-1658
- Lamp Holder Assembly, part number IRC60-0611 (qty 2)
- Fan Filter Assemblies, part number EQ-0082 (qty 3)



WARNING! Hazardous Voltage;

This equipment and Supply Cord operate at high voltages and current. Electric shock from any of these components can cause serious injury or death.

- Always remove the plug on the Supply Cord from the socket-outlet before performing any maintenance.
- Never spray water or other cleaning liquids on the equipment.



WARNING! Hot Surface(s);

This machine will get hot in use and can cause severe damage to equipment and serious injury to persons. Always allow the machine to cool for 15 minutes after use before performing any maintenance.

TO CHANGE THE UV LAMP



WARNING! Hot Surface(s);
WARNING! Serious Injury May Result;
UV Lamp and housing may be hot.

- Allow the Irradiator Module, UV lamp and surrounding surfaces to cool for at least 15 minutes before handling.
- Wear protective gloves.
- A broken UV Lamp can cause injury and will be contaminated with mercury. In this instance, refer to Safety, What to do if a UV Lamp Breaks section in this manual.

To remove the UV Lamp

- Remove the two Irradiator Cover Screws at either end of the Irradiator Module using a Phillips screwdriver tip size no. 2
- Pull the Irradiator Removal Handles to remove the inner housing.
- Turn inner housing upside down.
- Loosen or remove the four Screws retaining the UV Lamp End Caps using a 7/64 inch Hex L-Key.
- Remove the UV Lamp with care.

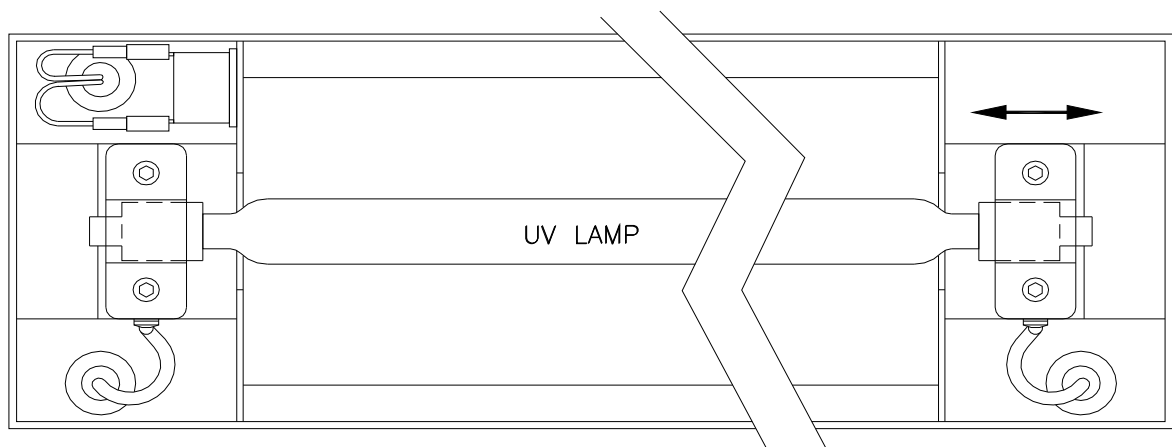

Fig. 16 Irradiator Underside View

Cleaning

- It is recommended to clean the reflector whenever the UV Lamp is changed. Use a paper towel moistened with Deionized (DI) Water.
- Do not touch a new UV Lamp with bare hands; this will reduce the lifespan of the UV Lamp. Always wear clean gloves. If a UV Lamp does require cleaning, use a paper towel moistened with Deionized (DI) Water.

UV Lamp installation (Opposite of Removal)

- Always use a manufacturer approved UV Lamp.
- Align the End Clamp brackets with the center of each End Cap. The brackets securing the Lamp End Caps are designed to move as the lamp expands and contracts in use. Do not tighten the brackets in the outermost position.
- Gently tighten the screws holding the End Cap; over-tightening may damage the UV Lamp.



NOTE

MAINTENANCE SCHEDULE

This equipment requires periodic inspection and cleaning. The frequency of inspections should be increased if the equipment is operated or stored in environmental conditions beyond those recommended in this manual.

PREPARATION FOR EACH USE

- Inspect the condition of the Supply Cord for signs of damage, cracking and aging. If damage is found, replace the cord before further use. Do not attempt to repair a damaged cord. Contact your distributor or manufacturer for a replacement cord or repair.
- Make sure the Fan Filters are clean. If the fan filters are blocked with dust, remove the Fan Filter Cover and take out the Filters. Rinse each Filter gently under a tap with cool water. Replace Filters if they are blocked with coating or damaged.
- Check the Cooling Fans on top of the Irradiator Module are unobstructed and operational.
- Ensure all ventilation slots and holes are unobstructed. Clean with a vacuum cleaner; do not use compressed air.
- Inspect the condition of the UV Lamp and Reflectors. If the UV Lamp has blackened ends extending for more than 1/2 inch [12mm] replacement may be necessary. White marks on the UV Lamp are a normal consequence of aging. If cleaning is required use a Paper Towel moistened with Deionized (DI) Water. Never touch the UV Lamp with bare hands. If necessary, replace the UV Lamp in the Irradiator Module following the removal and installation procedure in the How to Change a UV Lamp section in this manual. UV Lamps should be replaced after 800 hours of use.
- It may be necessary to clean the equipment exterior. Remove the plug on the Supply Cord from the socket-outlet. Use a vacuum cleaner and moistened Paper Towel to remove dust. Do not use chemical cleaning solutions. Do not immerse equipment or allow water to puddle. Use a separate Paper Towel to dry. Allow equipment to dry thoroughly before reconnecting the Supply Cord.
- It may be necessary to clean the Supply Cord before use. Remove the plug on the socket-outlet. Use a moistened Cotton Cloth or Paper Towel to remove dust. Do not use chemical cleaning solutions. Use a separate cloth to dry. Allow the Supply Cord to dry thoroughly before reconnecting to equipment.
- It may be necessary to clean the wheels before use. Consult your coating manufacturer for approved methods to remove coating from wheels.

EVERY 3 MONTHS

- Inspect the condition of the Wheel and Shutter assembly underneath the Irradiator Module.

TROUBLESHOOTING

Problem	Diagnosis/Remedies
Power Supply does not have power	<ul style="list-style-type: none"> • Ensure that the Supply Cord is correctly inserted into a suitable socket-outlet. • Check or reset the main Circuit Breaker for the socket-outlet.
Power On/Off Switch will not switch to the on position	<ul style="list-style-type: none"> • Ensure that the Emergency Stop Button on the Irradiator is twisted clockwise to the on position. • Make sure the Power Supply Covers are installed correctly. A safety Interlock Switch inside the Power Supply will prevent use if not engaged.
Machine has power but UV Lamp does not light when the Lamp Switch is on (White power indicator is on)	<ul style="list-style-type: none"> • If the system has been used within the last few minutes: <ul style="list-style-type: none"> ○ The UV Lamp may be too hot to start. Allow the cooling cycle to complete and retry. ○ The Thermal Switch inside the Irradiator may be too hot. A blue indicator lamp on top of the Irradiator will illuminate. The Thermal Switch will automatically reset when the Irradiator cools down to a safe temperature. This reason for the shutdown is most likely due to insufficient cooling. Refer to the User Maintenance section in this manual for instructions. • The UV Lamp may require replacement. Switch the machine off and unplug from the socket-outlet. Remove the Irradiator and check the UV Lamp for damage.
UV Lamp switches off during use	<ul style="list-style-type: none"> • Check all cable connectors are installed correctly and inspect cords for damage. • If the white Power Indicator on the Control Panel is off: <ul style="list-style-type: none"> ○ Check the status of the Power On/Off Switch. The circuit breaker function in this switch may have been activated. ○ Check or reset the main Circuit Breaker for the socket-outlet. ○ Check the Emergency Stop Button was not activated accidentally. • If the white Power Indicator on the Control Panel is on: <ul style="list-style-type: none"> ○ If the UV Lamp flickers before shut down, this may indicate the UV Lamp requires replacement. ○ The Thermal Switch inside the Irradiator may be too hot. A blue indicator lamp on top of the Irradiator will illuminate. The Thermal Switch will automatically reset when the Irradiator cools down to a safe temperature. This reason for the shutdown is most likely due to insufficient cooling. Refer to the User Maintenance section in this manual.

Problem	Diagnosis/Remedies
UV Lamp does not cure properly	<ul style="list-style-type: none"> • Ensure cure speed is appropriate to the UV coating. Consult your coating supplier for application recommendations. • Check the coating use-by date, make sure it has been mixed correctly and ensure the preparation and application parameters are correct, such as thickness, moisture level, acidity levels etc. • Check age of UV Lamp. UV Lamps should be replaced after 800 hours of use. • Check condition of UV Lamp. If the UV Lamp has blackened ends extending for more than 1/2 inch [12mm] replacement may be necessary. White marks on the UV Lamp are a normal consequence of aging. • Check Shutter is operating. If not, the Shutter Actuator may require replacement. • When the Shutter opens, check there is a change in UV Lamp brightness. If not, check the following: <ul style="list-style-type: none"> ○ With the UV Lamp off and the Shutter open, switch the Power Supply off and unplug the Supply Cord from the socket-outlet. View the underside of the Irradiator Module and locate the Shutter Actuator mounted on the axle between the front wheels. Check the shutter actuator is activating the micro-switch underneath the bottom cover (it may be necessary to remove the bottom cover). If the switch is not activated, adjustment or replacement is necessary.
Speed Display does not indicate speed	<ul style="list-style-type: none"> • Press the 'SEL' (select) button on the Speed Display to toggle between the Rate and Distance Counter modes. Rate mode is indicated by the letter 'R' on the left side of the screen.
Speed Display is erratic	<ul style="list-style-type: none"> • This may be a normal condition in the following circumstances: <ul style="list-style-type: none"> ○ At speeds below 30ft/min [9m/min]. ○ The floor surface is rough or uneven. ○ Operator may be unfamiliar with the equipment and maintaining a constant speed. • Front wheels may be covered in coating or debris and not rolling properly. Clean as required. • To test the speed sensor is working correctly: <ul style="list-style-type: none"> ○ Place two markers on the floor at 10 feet [3m] apart. Align the machine with one end marker. On the Speed Display, select the Distance Counter mode; press the 'SEL' (select) button until the 'R' on the left side of the screen is no longer visible. Press the 'RST' (reset) button. With the UV Lamp off, open the shutter and move the unit forward to the second marker. The Speed Display should reach a count of 10 feet or 3 meters by the second marker. • If the Speed Display stops working completely, the sensor head underneath the Irradiator Module may require adjustment. With the UV Lamp off, open the shutter and check the gap between the gear and the sensor. The gap should be less than 1/8 inch [3mm]. If it is not, contact your equipment dealer for further assistance.

Consult your equipment dealer for further assistance or replacement parts.

SPECIFICATIONS

Model	Input Voltage	Frequency	Current
JFC-412EX	208VAC	60Hz	15A
	230VAC	50Hz	15A
	230VAC	50Hz	10A
Parameter		Value	
Ambient Operating Temperature		40-115°F [5-46°C]	
Ambient Operating Humidity		20-90% (with no condensation)	
Ambient Storage Temperature		40-115°F [5-46°C]	
Ambient Storage Humidity		20-90% (with no condensation)	
Sound Pressure Level LPA		< 75dB(A)	
Minimum Dimensions (Length x Width x Height)		20 x17 x 30 inches [500 x 430 x 760mm]	
Weight		40lb [18kg]	

Specifications



Jelight Company, Inc.

2 Mason, Irvine, CA 92618 U.S.A.
1-949-380-8774

LIMITED WARRANTY

What does this warranty cover?

This warranty covers any defects in materials and workmanship to the original end-user purchaser of this product with the exceptions stated below, provided the Warranty Registration Form has been returned to Jelight Company, Inc.

What does this warranty not cover?

This warranty does not cover damage or loss of parts incurred in transit, by abuse, misuse or an act of God (such as a flood), modifications (such as the installation and use of non-approved UV Lamps or other components), damage incurred through contact with oils or chemicals other than those specified in this manual when used as directed, any component that has been subject to unusual physical or electrical stress and consumable items (such as fan filters and capacitors). Also, consequential and incidental damages are not recoverable under this warranty. This warranty is non-transferable.

What is the period of coverage?

This warranty covers non-consumable components for a period of 12 months following the date of purchase, with the following exception:
The UV Lamp is covered for 3 months or 500 hours of use, whichever comes first.

What will Jelight Company, Inc. do to correct problems?

We will inspect your product and contact you within three days of receipt to advise the results of our inspection. If the product qualifies for warranty repair, Jelight Company, Inc. will elect whether to provide replacement parts and labor free of charge or replace the unit. If the product does not qualify for warranty repair, Jelight Company, Inc. will provide an estimate of the parts, labor and shipping charges required to complete the repair and return the product. If you authorize repairs, Jelight Company, Inc. will fix the product and return it within 21 days.

How can you get warranty service?

Contact Jelight Company, Inc. at the telephone number above for technical support and provide contact details, product name, serial number and date of purchase. If field repair is not possible, a Return Material Authorization (RMA) Number will be issued. This RMA number must be indicated on all shipping labels, documentation and communications relating to this repair.

Send the product to: Jelight Company, Inc.
2 Mason, Irvine, CA 92618
U.S.A.

How will state law affect your customer's rights under the warranty?

This warranty gives you specific legal rights, and you may also have other rights which vary from state to state.

Record your product information

Please record the information below and retain this for warranty service.

Date of Purchase	
Model Name / Number	
Serial Number	

Disclaimer:

Jelight Company Inc. warrants only that a product will conform to its physical descriptions, makes no other warranties and expressly disclaims any implied warranty of fitness for a particular reason. It is the responsibility of the purchaser to determine the suitability of the product for any purpose. All information provided by Jelight Company, Inc. is in good faith and when offered by another manufacturer or source is done so in good faith. In the event a warranty is offered by another manufacturer of goods or services, such warranty will convey from that manufacturer.

Jelight Company Inc. reserves the right to modify or discontinue this product at any time. All texts, graphics and logos in this manual are for guidance purposes and may be changed without notice. Jelight Company Inc. reserves the right to amend all or some of these terms and conditions at any time. Jelight Company Inc. declines all liability in the matter, as well as all responsibility for the accuracy, timeliness and/or completeness of the information contained, and for any use made of the information provided. Jelight Company Inc. assumes no obligation to update the data provided or to correct any errors. No rights may be relied from the information provided. Jelight Company Inc. and/or its rightful claimants, retains all rights (including copyright, trade mark and patent rights) in the material presented in this manual. No form of license is granted to the information. In particular, reproduction or making the content of this manual available to others in any form is strictly prohibited without prior written permission from Jelight Company Inc. Any unauthorized reproduction of art work is subject to legal action; and is protected by Federal, State and Local law.

In no event shall Jelight Company Inc. be responsible for particular, minor or significant damage, directly or indirectly, whether the claim is in contract, negligence or otherwise (including but not limited to, any interruption of service, loss of business, anticipated profit, or other consequential damages arising out of the use or inability to use this product or from any defect or omission in the manual, or other related items). In no event shall the liability of Jelight Company, Inc. exceed the purchase price of the product. These terms and disclaimer shall be governed by and interpreted in accordance with the laws of the United States.

© Copyright 2010 Jelight Company, Inc.



Jelight Company, Inc.

2 Mason, Irvine, CA 92618 U.S.A.
1-949-380-8774

WARRANTY REGISTRATION FORM

Registration entitles you to product support and notification of product upgrades and enhancements. We do not sell your name to third party mailing list companies. Information you provide is for the exclusive use of Jelight Company, Inc.

Please complete and return this form by surface mail to Jelight Company Inc. Alternatively, you may e-mail this information to warranty@jelight.com

Name	
Title	
Company	
Telephone	
E-mail	
Street Address	
City	
State / Province	
Zip / Postal Code	
Country	
Date of Purchase	
Model Name / Number	
Serial Number	

THIS PAGE INTENTIONALLY LEFT BLANK

APPENDIX A – APPLICABLE TO SOME REGIONS ONLY

CONNECT JFC-412EX TO TWO 115VAC, 15A SOCKET OUTLETS

INSTRUCTIONS:

1. ONLY CONNECT TO CORRECTLY WIRED SOCKET OUTLETS: TEST WITH GFI RECEPTACLE TESTER. THE TESTER WILL DISPLAY TWO AMBER LIGHTS WHEN CORRECT.
2. CONNECT CABLES AS SHOWN IN THE DIAGRAM BELOW.
3. SOCKET OUTLET CIRCUITS MUST BE OUT OF PHASE: THE READY INDICATOR ON THE CONVERTER WILL ILLUMINATE WHEN CORRECT.
4. ON THE VOLTAGE CONVERTER, SWITCH THE BREAKER TO THE ON POSITION.
5. FOLLOW JFC-412EX OPERATING INSTRUCTIONS.

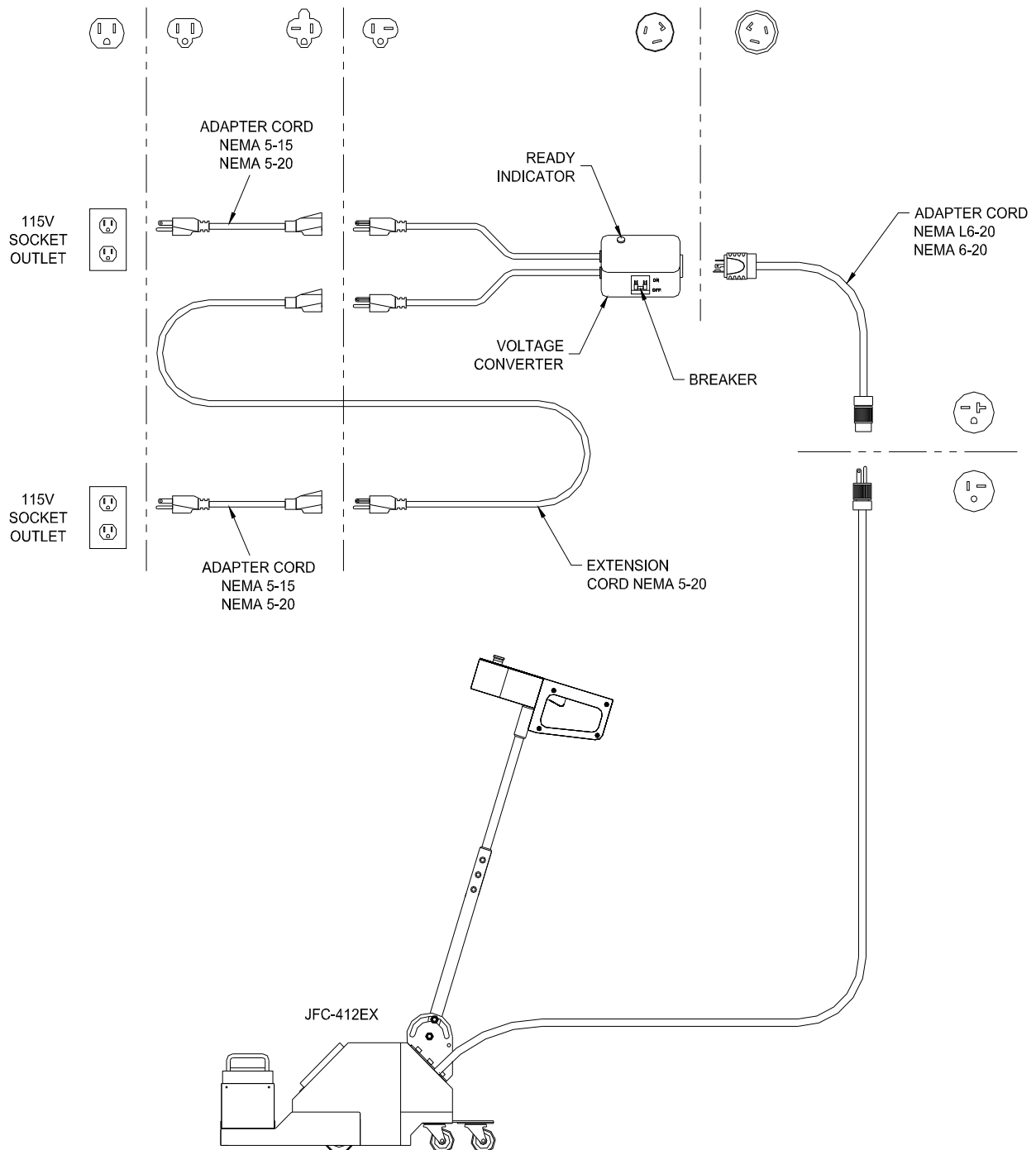

APPENDIX B

