



Jelight Company, Inc.

2 Mason, Irvine CA 92618 USA

Tel: +1-949-380-8774

Fax: +1-949-768-9457

<http://www.jelight.com>

e-mail: sales@jelight.com

OPERATING INSTRUCTIONS

JUVC-5B

Curing System



Original Instructions Rev E

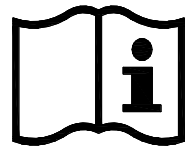

TABLE OF CONTENTS

Page	Title
3	INTRODUCTION
4	ICONS USED IN THIS MANUAL
 Warning Icons
5 General Advisory Icons
 Informative Icons
6	EQUIPMENT SAFETY LABELS
7	EQUIPMENT SERIAL NUMBERS
8	SAFETY GUIDE
 Equipment Caution and Warning Labels
 Risk of Explosion
9 Basic Precautions
 Risk of Fire
 Hot Surface(s)
10 Hazardous Voltage
 Grounding Instructions
 Pinch Point, Crush Hazard
11 Ultraviolet (UV) Light
12 UV Protective Garments and Warning Sign
13 Ozone Inhalation Hazard
 What to do if the UV Lamp Breaks
14 Moving Instructions
15 Storage Instructions
 Save These Instructions
16	CONTROLS AND CONNECTIONS
 Power Supply Control Panel
17 Irradiator
18	OPERATING INSTRUCTIONS
 Connect Power Cords
 To Start the UV Lamp
20 Standby Mode
 To Switch the UV Lamp Off
21	TRAINING INSTRUCTIONS
 Planning
 Receiving the Curing Machine
 Unpacking the Curing Machine
22 Before Each Use
 Before Applying Coating
 Cure Height
23 Cure Width
 Cure Overlap
24 Curing Example
27	USER-MAINTENANCE INSTRUCTIONS
 Recommended Tools and Supplies
 Optional Tools
 Recommended Spare Parts
28 To Change the UV Lamp
29 Maintenance Schedule
 Preparation for Each Use
 Every 3 months
30	TROUBLESHOOTING
31	SPECIFICATIONS
32	LIMITED WARRANTY
34	WARRANTY REGISTRATION FORM
36	APPENDIX A: CAUTION SIGN (copy as required)

INTRODUCTION

The JUVIC-5B Curing System consists of a lightweight Power Supply, high intensity Ultraviolet (UV) Light Irradiator and Docking Station. The Irradiator provides a significant UV light source for fast and efficient curing and the Docking Station allows temporary placement of the Irradiator without having to extinguish the lamp.

JUVIC-5B comes standard with a cable storage tray and folding carry handle for ease of movement and storage. Both the Power Supply and Irradiator are fitted with a series of safety features to protect the user and prevent damage to the system.

This manual contains instructions for the safe setup and operation of this Power Supply and Irradiator. Please read and follow this instruction manual carefully before use to maximize machine performance and to avoid the risk of safety hazards.



Fig. 1

ICONS USED IN THIS MANUAL

WARNING ICONS



WARNING! Severe equipment damage, serious injury or death may result



DANGER! Risk Of Explosion
WARNING! Risk Of Explosion



WARNING! Risk Of Fire



WARNING! Hazardous Voltage



WARNING! Hot Surface



WARNING! Ultraviolet Light



WARNING! Inhalation Hazard



WARNING! Poison



WARNING! Lifting Hazard



WARNING! Pinch Point, Crush Hazard

GENERAL ADVISORY ICONS



NOTE

General Advisories -
operational procedures, order of
operation, etc



Wear UV Face Shield



Wear Protective Clothing



Wear Protective Gloves



Wear Safety Boots



Wear Respirator



Do Not Place Electronic Waste
in the Trash



Do not Stack

INFORMATIVE ICONS



Operator's Manual;
Operating Instructions

EQUIPMENT SAFETY LABELS

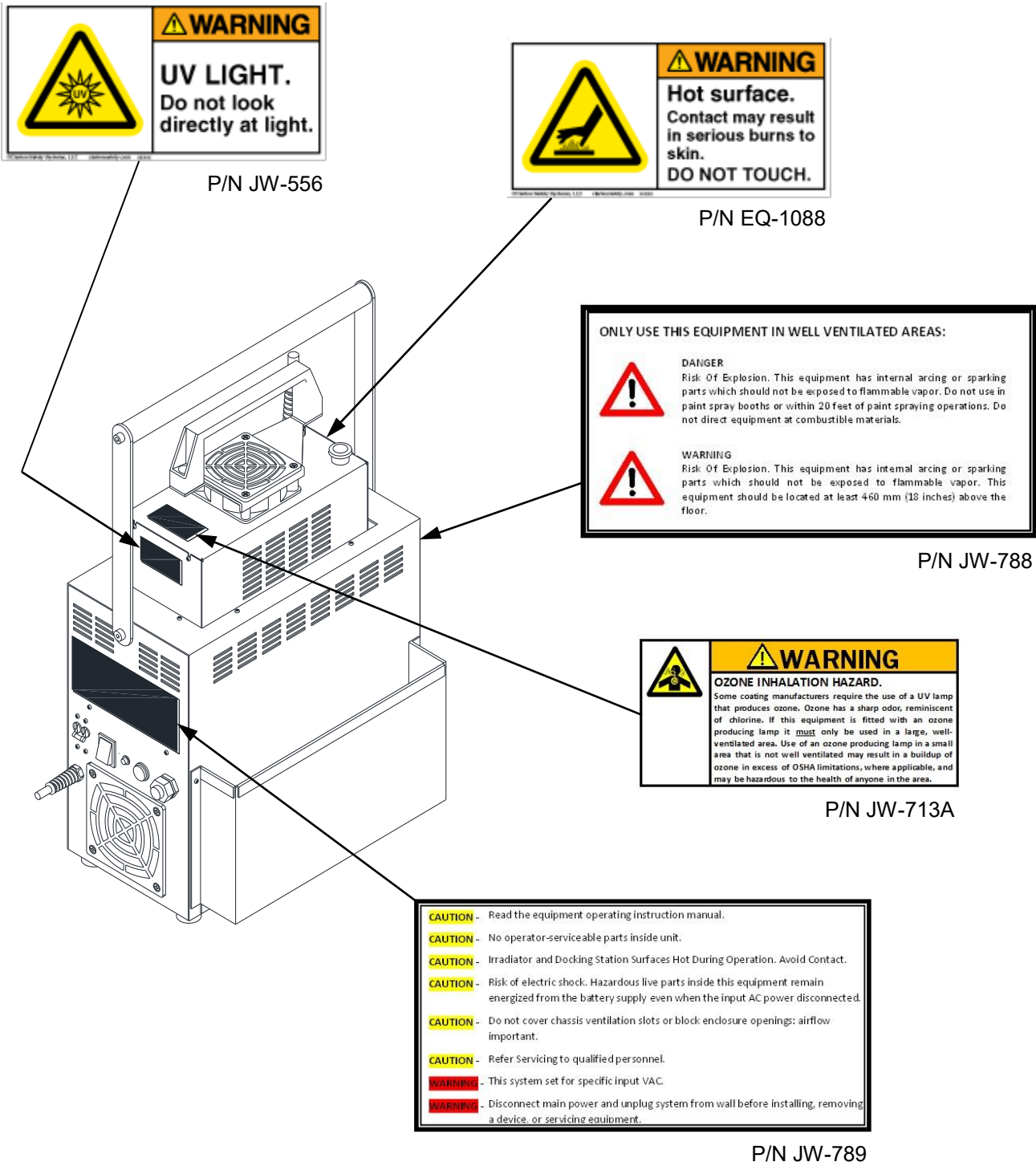

Fig. 2
Equipment Safety Label Locations

EQUIPMENT SERIAL NUMBERS

Machine:

The equipment Serial Number is indicated at the rear of the Power Supply and on top of the Irradiator. In the example shown in Fig. 3, the Serial Number is B000.

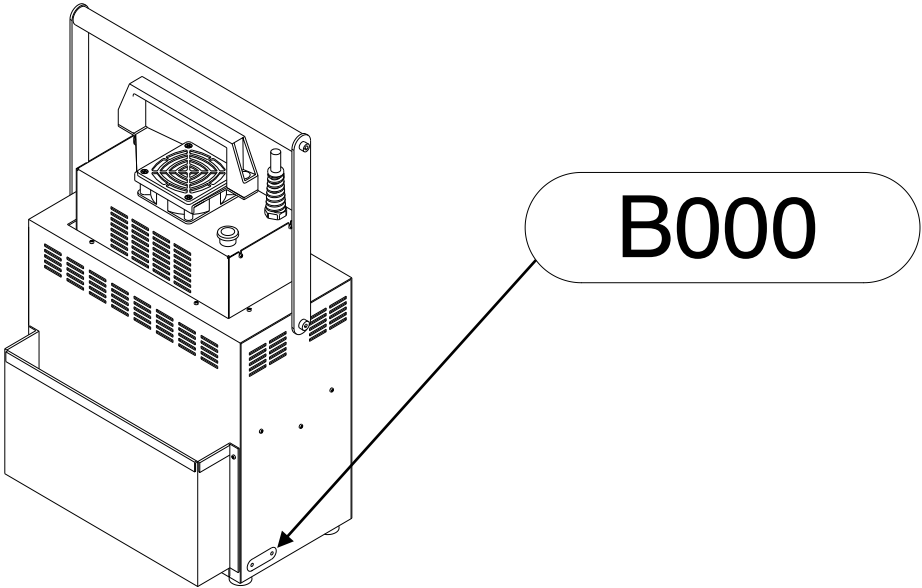

Fig. 3 Machine Serial Number

UV Lamp:

The UV Lamp has a four-digit Part Number, preceded by the letters UVC. There is also a five-digit Serial Number etched below the part number. In the example shown in Fig 4, the Part Number UVC1427 and Serial Number is 12345.

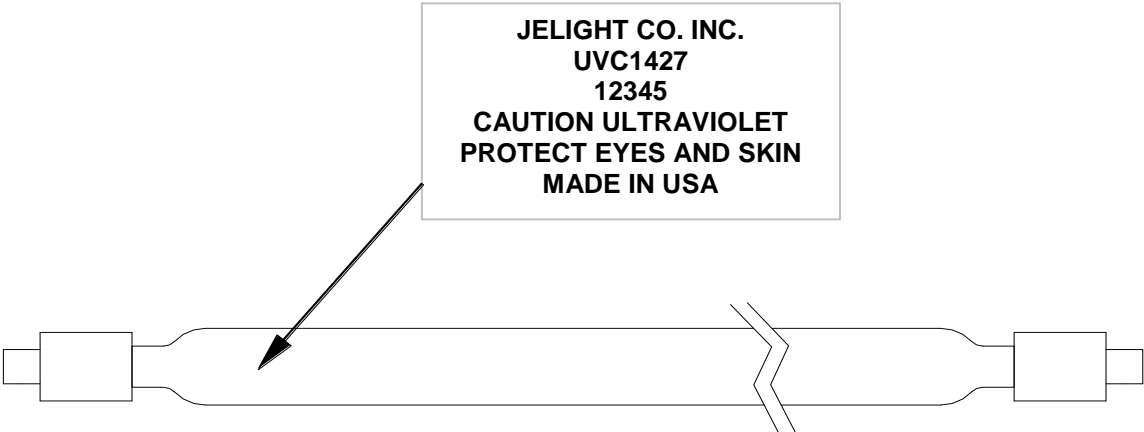

Fig. 4 UV Lamp Serial Number

SAFETY GUIDE



IMPORTANT SAFETY INSTRUCTIONS SAVE THESE INSTRUCTIONS

INSTRUCTIONS PERTAINING TO A RISK OF FIRE, ELECTRIC SHOCK, OR INJURY TO PERSONS

1. Read and pay attention to all caution and warning labels on the equipment.

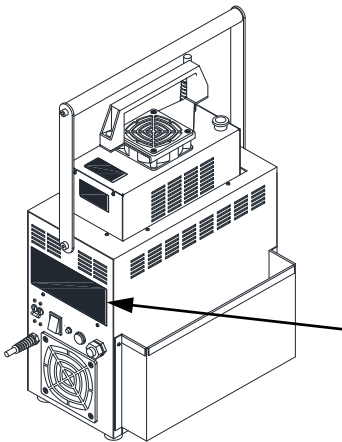

- CAUTION** - Read the equipment operating instruction manual.
- CAUTION** - No operator-serviceable parts inside unit.
- CAUTION** - Irradiator and Docking Station Surfaces Hot During Operation. Avoid Contact.
- CAUTION** - Risk of electric shock. Hazardous live parts inside this equipment remain energized from the battery supply even when the input AC power disconnected.
- CAUTION** - Do not cover chassis ventilation slots or block enclosure openings: airflow important.
- CAUTION** - Refer Servicing to qualified personnel.
- WARNING** - This system set for specific input VAC.
- WARNING** - Disconnect main power and unplug system from wall before installing, removing a device, or servicing equipment.

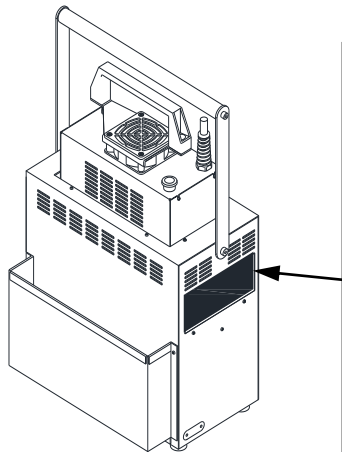

ONLY USE THIS EQUIPMENT IN WELL VENTILATED AREAS:



DANGER

Risk Of Explosion. This equipment has internal arcing or sparking parts which should not be exposed to flammable vapor. Do not use in paint spray booths or within 20 feet of paint spraying operations. Do not direct equipment at combustible materials.



WARNING

Risk Of Explosion. This equipment has internal arcing or sparking parts which should not be exposed to flammable vapor. This equipment should be located at least 460 mm (18 inches) above the floor.



2. WARNING! When using electric equipment, basic precautions should always be followed, including the following;

- a. This equipment is to be used only by qualified and trained personnel. See the Training section in this manual.
- b. This equipment is not intended for use by persons (including children) with reduced physical, sensory or mental capabilities, or lack of experience and knowledge, unless they have been given supervision or instruction concerning use of the appliance by a person responsible for their safety.
- c. Know how to turn off the product. Be thoroughly familiar with the controls.
- d. Stay alert – watch what you are doing.
- e. Do not operate the product when fatigued or under the influence of alcohol or drugs.
- f. Do not operate equipment or enter the work area if nursing or pregnant.
- g. Do not operate if you suspect there is a problem with the equipment. Have the equipment checked by a qualified technician.
- h. Do not place the equipment on an unstable surface.
- i. Follow the maintenance instructions specified in the manual.
- j. Store these instructions in an area provided on the equipment.



3. WARNING! Risk Of Fire;

- a. This equipment directs highly focused light below the Irradiator. This can ignite UV curable coatings and cause significant damage to curing surfaces.
- b. Use only manufacturer approved supply cords. Incorrectly rated supply cords can pose a fire hazard.
- c. Do not block or cover any ventilation slots on the machine.
- d. Allow the machine at least 15 minutes to cool before lifting or packing the machine for transit.



4. WARNING! Hot Surface(s);

This machine will get hot in use and can cause severe damage to equipment and serious injury to persons.

- a. Allow the Irradiator fans to continue cooling for 2 minutes after the UV Lamp is switched off.
- b. Allow the Irradiator, UV Lamp and surrounding surfaces to cool for at least 15 minutes before removing the cover to perform maintenance. Components will be hot. Wear protective gloves.
- c. Allow the Power Supply to cool for at least 15 minutes before removing the cover to perform maintenance. Electrical components will be hot.
- d. The curing area and nearby work surfaces will be hot.
- e. Allow the machine at least 15 minutes to cool before lifting or packing the machine for transit.



5. WARNING! Hazardous Voltage;

This equipment and power cord operate at high voltages and current. Electric shock from any of these components can cause serious injury or death.

- k. This machine operates in 2-pole, 3-wire configuration. Connection of other devices between this equipment and the circuit breaker protecting the socket outlet is not recommended.
- l. This equipment is for dry use only and shall not be used or stored outdoors in wet conditions.
- m. Do not allow the power cord to rest on wet surfaces.
- n. Observe warnings and directions on all warning labels and instruction labels located outside and inside the equipment.
- o. Remove the plug on the Supply Cord from the socket-outlet before cleaning the equipment or performing maintenance.
- p. Do not use equipment with a damaged cord, loose wires or broken plugs, receptacles or socket-outlets.
- q. Do not attempt to repair a damaged cord. Contact the manufacturer for a replacement.
- r. Do not remove plug from socket-outlet while the UV Lamp is switched on.
- s. Do not operate with any cover open or removed.
- t. Do not bypass any safety interlock switches on this equipment.

GROUNDING INSTRUCTIONS

- a. This equipment must be grounded while in use to protect the operator from electric shock. If it should malfunction or breakdown, grounding provides a path of least resistance for electric current to reduce the risk of electric shock. This equipment is provided with a three-conductor cord and a three-contact grounding type attachment plug to fit the proper grounding type receptacle. The green (or green and yellow) conductor in the cord is the grounding wire. Never connect this wire to other than the grounding pin of the attachment plug. The plug must be plugged into an appropriate socket-outlet that is properly installed and grounded in accordance with all local codes and ordinances.
- b. Improper connection of the equipment grounding conductor is able to result in a risk of electric shock. Check with a qualified electrician or serviceman if you are in doubt as to whether the equipment is properly grounded. Do not modify the plug provided with the equipment – if it will not fit the socket-outlet, have a proper socket-outlet installed by a qualified electrician.



6. WARNING! Pinch Point, Crush Hazard;

- a. Use caution when placing the Irradiator into the Docking Station and operating the Latch mechanism.
- b. Use caution when installing a UV Lamp into the Irradiator.



7. WARNING! Ultraviolet (UV) Light;

Exposure to UV radiation is hazardous and can cause severe equipment damage, serious injury to skin, eyes and immune system or death.

- a. Place UV warning signs in prominent locations and cordon off work area with protective measures such as curtains or shutters. The work area is typically the room in which UV curing takes place – see Fig. 5.
- b. Do not permit animals into the work area.
- c. Mask nearby surfaces and equipment to prevent damage by UV light.
- d. This equipment requires one qualified operator. No other persons should be permitted into the work area while the equipment is in use.
- e. All persons in the work area must be made aware of the danger zone – see Fig. 5.
- f. Do not start the machine unless all persons in the danger zone are wearing UV protective face shields and garments providing full skin coverage – see Fig. 6.
- g. Do not start the machine unless all persons in the work area are wearing UV protective goggles and full-length garments.
- h. Ensure that persons without UV protective eyewear and garments stay outside the work area.
- i. Do not look directly at UV light.
- j. Never hold the Irradiator in a manner to expose bystanders to direct UV light.
- k. When the equipment is in Standby mode, some UV light is still visible inside the Irradiator and Docking Station. Do not remove UV protective Face Shield or garments or allow unprotected individuals into the work area while the machine is on.

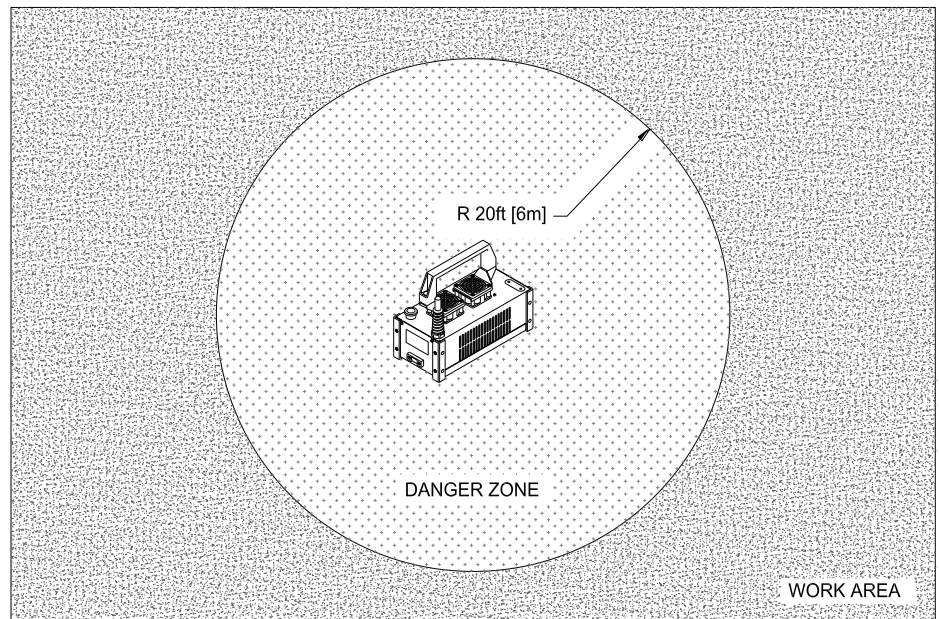

Fig. 5 Work Area and Danger Zone



Fig. 6
UV Protective Garments and Warning Sign



8. WARNING! Ozone Inhalation Hazard

Some coating manufacturers require the use of a UV lamp that produces ozone. Ozone has a sharp odor, reminiscent of chlorine. If this equipment is fitted with an ozone producing lamp it must only be used in a large, well-ventilated area. Use of an ozone producing lamp in a small area that is not well ventilated may result in a buildup of ozone in excess of OSHA limitations, where applicable, and may be hazardous to the health of anyone in the area.



9. WHAT TO DO IF THE UV LAMP BREAKS

WARNING! Inhalation Hazard;

WARNING! Poison;

WARNING! Hot Surface(s);

The UV Lamp used in this curing system contains mercury, a substance known to be hazardous to health and the environment. Always handle UV Lamps with care and wear gloves.



It may be necessary to contact your local municipality for information regarding the cleanup of mercury spills; it may not be legal to perform this task yourself. The following guidelines are for instances where cleanup can be performed by the operator. Suggested provisions are indicated in the User Maintenance, Recommended Tools and Supplies, Clean-Up Kit section in this instruction manual.



9a. When indoors; before clean-up, air out the room

- i. Evacuate the room, avoiding the breakage area as far as possible on the way out.
- ii. Open a window or door and vent the room to the out of doors for 15 minutes or more after evacuation.
- iii. Shut off central forced-air heating/air conditioning or any other internal air circulation system.
- iv. Wear chemically protective gloves, clothing and footwear. Use of a respirator is recommended.



9b. Clean-up steps for hard surfaces

- i. Do not use a vacuum or broom to clean up a broken UV Lamp.
- ii. Open a Newspaper and place 5 sheets on the floor next to the contaminated area.
- iii. Using a piece of cardboard approximately 6 inches [150mm] square to carefully scoop glass pieces and powder into a Dustpan. Place the broken pieces in the center of the Newspaper.
- iv. Carefully fold the corners of the Newspaper to the center to encapsulate all glass and powder fragments. Use Sticky Tape to fasten the corners and open edges of the Newspaper. Place Newspaper into the Biohazard Bag.
- v. Place the cardboard into the Biohazard Bag.
- vi. Use sticky tape to pick up any remaining small glass fragments and powder. Place dirty Sticky Tape into the Biohazard Bag.
- vii. Wipe the Dustpan and the floor area clean with damp Paper Towels. Place used Paper Towels into the Biohazard Bag.



9c. Clean-up steps for absorbent surfaces

- i. If a spill occurs on an absorbent surface such as carpet, cut and remove the contaminated portion and place in into the Biohazard Bag.

9d. Clean-up steps for the Irradiator

- i. Switch the equipment off. Remove the plug on the Supply Cord from the socket-outlet.
- ii. Equipment may be hot. Allow at least 15 minutes before handling Irradiator or UV Lamp.
- iii. Open a Newspaper and place 5 sheets on the floor next to the Irradiator.
- iv. Refer to User-Maintenance Instructions, To Change a UV Lamp section in this manual. At arms-length, remove the Irradiator Cover. Do not inhale any mercury vapor that may be present.
- v. Place glass pieces in the center of the Newspaper.
- vi. Remove the UV Lamp Metal End Caps from the Retaining Brackets and place in the center of the Newspaper.
- vii. Carefully fold the corners of the Newspaper to the center to encapsulate all glass and powder fragments. Use Sticky Tape to fasten the corners and open edges of the Newspaper. Place Newspaper into the Biohazard Bag.
- viii. Use Sticky Tape to remove any remaining small glass fragments and powder from the Irradiator and the Shutter. Place dirty Sticky Tape into the Biohazard Bag.
- ix. Wipe Irradiator and Cover clean with damp Paper Towels. Place used Paper Towels into the Biohazard Bag.



9e. Disposal of clean-up materials

- i. Seal the top of the Biohazard Bag with Sticky Tape.
- ii. If the Biohazard Bag is torn, reseal the broken area with Sticky Tape and place into a second Biohazard Bag.
- iii. Immediately place all clean-up materials outdoors in a protected area.
- iv. Check with your local or state government about disposal requirements in your specific area. Some states do not allow trash disposal. Instead, they require that broken and unbroken mercury-containing UV Lamps be taken to a local recycling center.
- v. Thoroughly wash your hands with soap after disposing of the Biohazard Bags containing clean-up materials.



10. MOVING INSTRUCTIONS

WARNING! Lifting Hazard;

WARNING! Hot Surface(s);

This equipment is heavy; refer to the Specifications section in this manual. Inappropriate handling may result in back injury and/or damage to the machine.

- a. Wear protective gloves.
- b. Wear safety boots.
- c. Remove the plug on the Supply Cord from the socket-outlet before moving.
- d. UV Lamp and housing may be hot. Always allow the Irradiator and Docking Station to cool for 15 minutes before lifting.
- e. Always secure the equipment with tie down straps during transportation.



11. STORAGE INSTRUCTIONS

- a. Refer to the Specifications section in this manual for recommended storage temperature and humidity ranges.
- b. Do not place into storage until equipment has fully cooled. Allow at least 15 minutes of cooling time before covering.
- c. Cover equipment to prevent dust from entering ventilation slots and holes.
- d. Do not stack equipment; keep on a level surface and do not store other equipment or coatings on top of the machine.
- e. Do not store outdoors.
- f. Do not allow equipment to get wet.
- g. Keep equipment away from chemicals.
- h. Store additional UV Lamps in the protective packaging provided.

12. SAVE THESE INSTRUCTIONS

Store these Operating Instructions with the equipment.

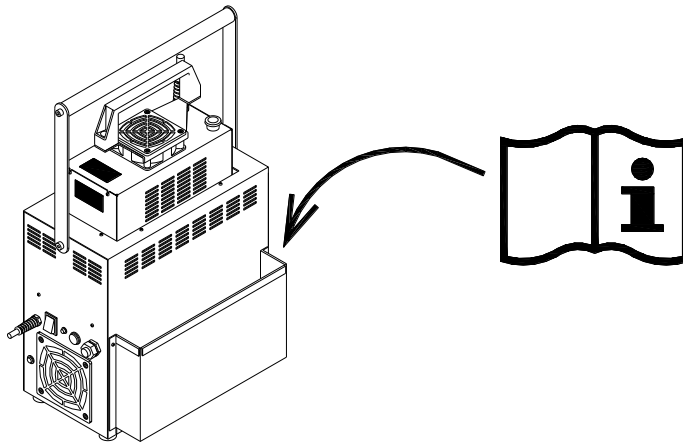

Fig. 7 Store Operating Instructions with Equipment

CONTROLS & CONNECTIONS

POWER SUPPLY CONTROL PANEL

Power On/Off Switch	Push to switch the Curing System on or off.
Power Indicator	The white Power Indicator illuminates when the UV Lamp is switched on.
Start Button	Press this button to start the UV Lamp.
Circuit Breaker	This protects the Power Supply from overload. If the toggle actuator (handle) is in the down position the machine will be disabled. To reset, move the toggle actuator to the up position.
Input Cord	Connect to a socket outlet rated for use with this equipment. Refer to the Specifications section in this manual.
Output Cord	This cord supplies power to the Irradiator.
Fan	The Ventilation Fan draws air into the Power Supply.

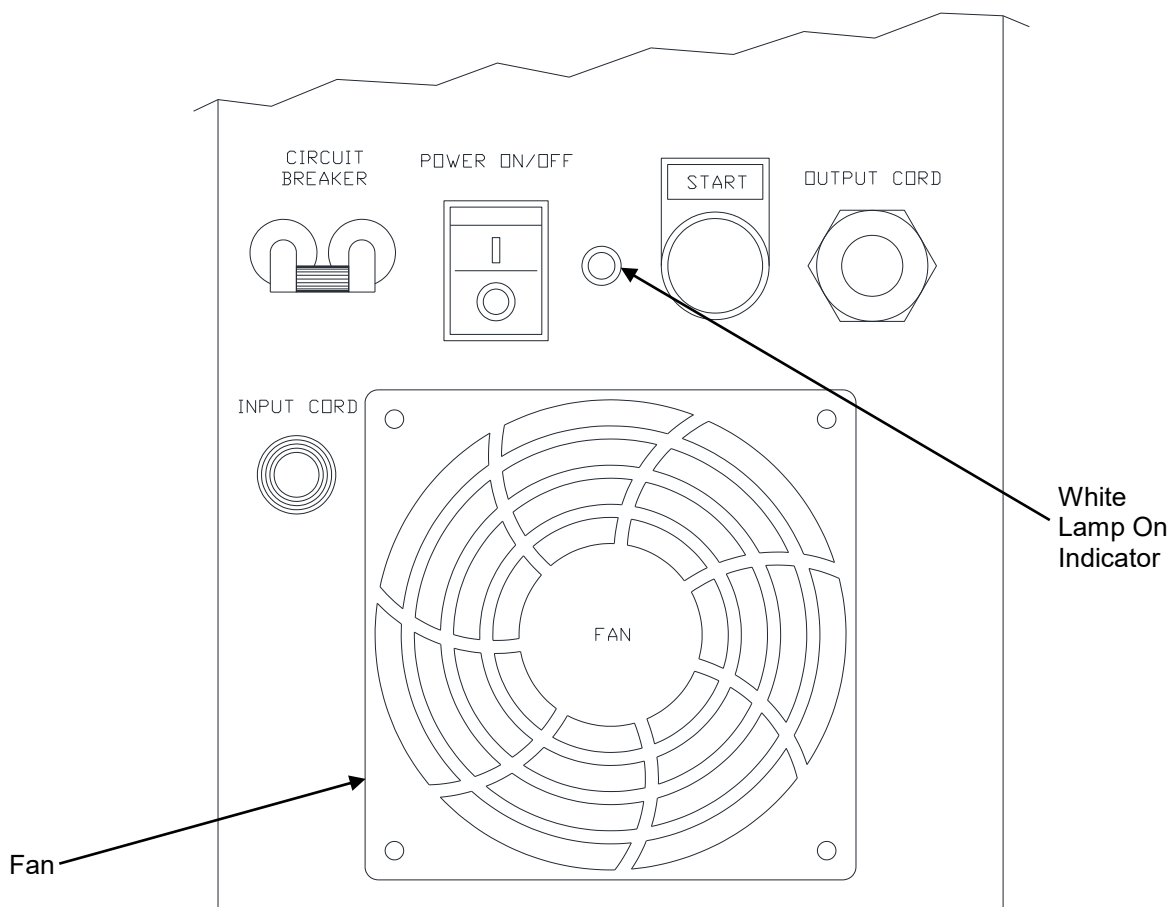

Fig. 8 Control Panel

IRRADIATOR

Power Cord	Connect to the Power Output Receptacle on the Power Supply only when the Power Supply Inlet cord is unplugged.
Emergency Stop Button	Push this button to shut the Power Supply down in case of an emergency. Twist clockwise to reset.
Irradiator Fan	This fan provides cooling for the UV Lamp and components.
Fan Start Switch	(Not Visible): The switch is located inside the Irradiator and will start the fan approximately two minutes after the lamp ignites.
Thermal Switch	(Not Visible) The switch is located inside the Irradiator and will turn off the Power Supply if the Irradiator overheats.

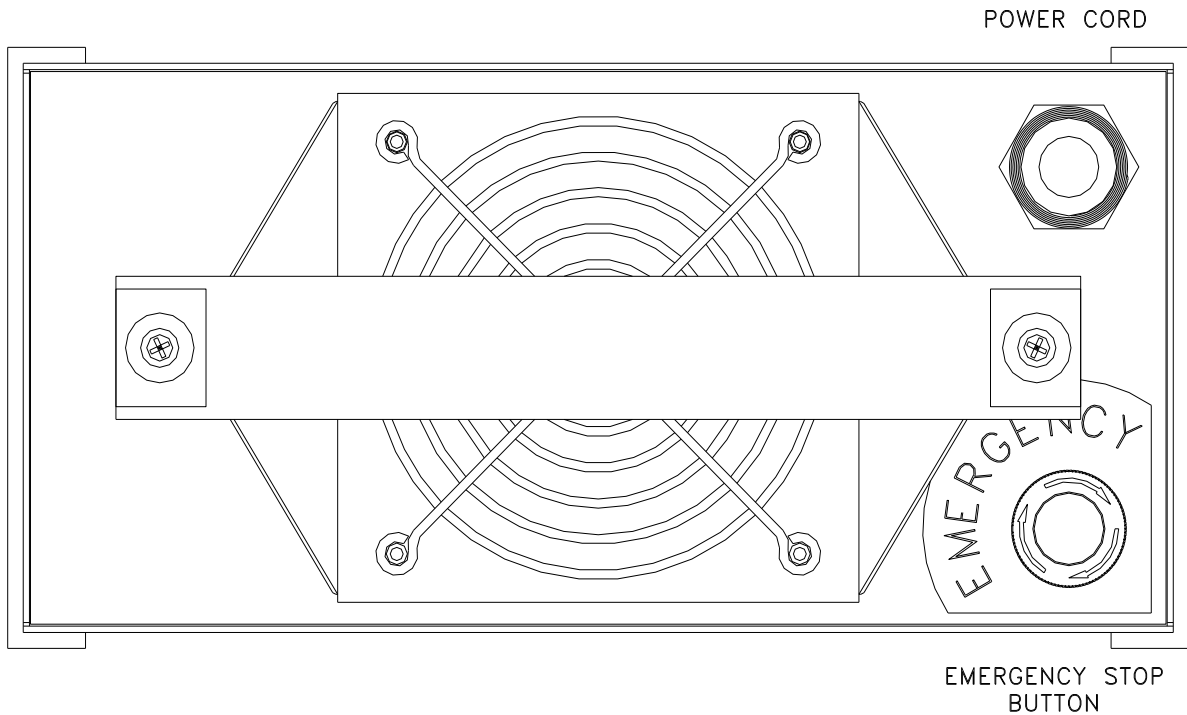

Fig. 9 Irradiator Plan View

OPERATING INSTRUCTIONS



CONNECT POWER CORD

- Ensure the Power Supply On/Off Switch is in the off position.
- Uncoil all power cords.
- Connect the plug on the Supply Cord to a socket-outlet.

WARNING! Severe Equipment Damage, Serious Injury Or Death May Result;

In Case of Emergency, push the Emergency Stop Button on the Irradiator. Move the Power On/Off Switch to the off position and unplug the Power Supply. To restart the Curing System, twist the Emergency Stop Button clockwise.

WARNING! Severe Equipment Damage, Serious Injury Or Death May Result;

When the UV Lamp is on and the Irradiator is removed from the Docking Station, the UV Lamp will emit high energy UV light and heat. This can result in extremely high temperatures and potential for fire. Damage to surfaces, coatings and equipment may result. Ensure the Irradiator is kept in motion at all times.

TO START THE UV LAMP

- All persons in the work area must wear UV protective garments and Face Shields before starting the UV Lamp.
- Ensure the Irradiator is installed in the Docking Station – see Fig. 10. Install the Irradiator into the tray on top of the Docking Station: Insert the bottom bumper of the Irradiator under the plate at the end of the Docking Station tray. Lower the opposite end of the Irradiator into the tray, engaging the latch.

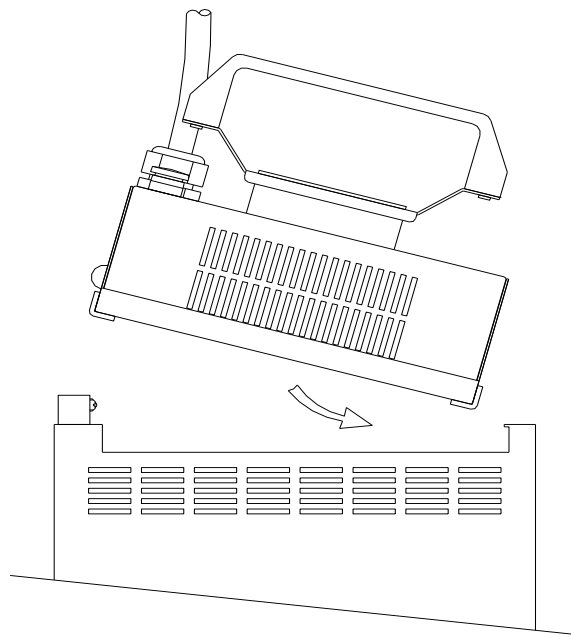

Fig. 10 Install Irradiator into the Docking Station

- On the Power Supply, move the Power On/Off Switch to the on position.
 - The cooling fan on the Power Supply will operate. If the fan on the Power Supply does not start, twist the Emergency Stop Button clockwise to the On position.
- Press the green Start Button for about 1 second.
 - The white Power Indicator next to the Power On/Off Switch will illuminate. If the White Power Indicator does not illuminate, refer to the Troubleshooting section in this manual.
 - The UV Lamp inside the Irradiator Module will light. If the UV Lamp does not light, press the green Start Button again. If the UV lamp does not light after several attempts, refer to the Troubleshooting section in this instruction manual.
 - After approximately 3-5 minutes, the cooling fan on top of the Irradiator will operate. When the cooling fan starts the Curing Machine is ready for use. At this time, the system is in Standby Mode.
- Remove the Irradiator from the Docking Station; lift the Irradiator at the latch end first. Always hold the Irradiator facing downwards. Do not look directly at the UV lamp. See Fig. 11.

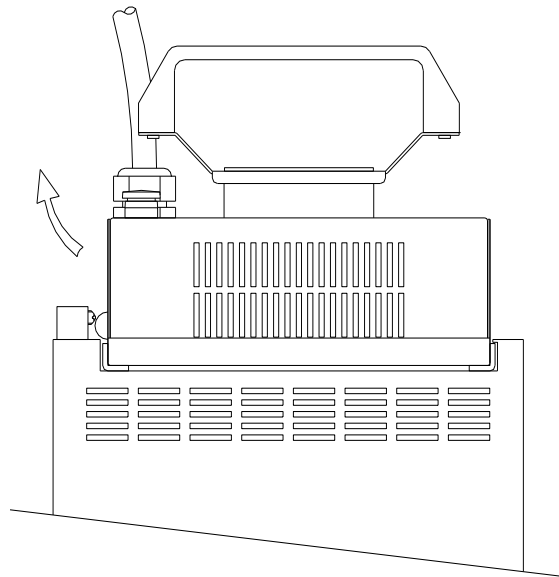

Fig. 11 Remove Irradiator from Docking Station

- Unless otherwise directed by your coating supplier, move the Irradiator in a slow sweeping motion, approximately 2 Inches [50mm] above the surface to cure. Several passes may be required before the material is fully hardened. Use caution, the Irradiator and the work surface will become hot.

STANDBY MODE

When the Irradiator is installed onto the Docking Station, the UV lamp will be in Standby Mode. In Standby Mode the UV Lamp will continue to emit high energy UV light and heat. This can result in extremely high housing temperatures and potential for fire.



WARNING! Severe Equipment Damage Or Serious Injury May Result;

ALWAYS place the Irradiator into the tray on top of the Docking Station and engage the latch. Never rest the Irradiator on work surfaces; severe heat damage or fire may occur.



WARNING! Severe Equipment Damage, Serious Injury Or Death May Result;

The Docking Station is a temporary resting place for the Irradiator during intermittent use. Continued use of the Docking Station may cause an overheat condition and cause the Irradiator and Power Supply to switch off.



WARNING! Severe Equipment Damage Or Serious Injury May Result;

When the Irradiator is installed onto the Docking Station, UV light will still be visible inside the Irradiator. Do not remove Face Shield, protective clothing or allow any unprotected persons or animals into the work area. Refer to the Safety section in this manual for further details.

- Place the Irradiator into the Docking Station.
- If Standby Mode duration is likely to exceed 15 minutes, on the Power Supply, move the Power On/Off Switch to the Off position. The UV Lamp will cool down and can be restarted after approximately 5 minutes.



WARNING! Hot Surface(s);

Irradiator, UV Lamp and Docking station will be hot after use. Allow the machine to cool for 15 minutes before handling.

TO SWITCH THE UV LAMP OFF

- When the curing task is complete, or if Standby Mode is likely to exceed 15 minutes, on the Power Supply move Power On/Off Switch to the off position.
- Disconnect the Supply Cord from the socket-outlet.

TRAINING INSTRUCTIONS



The following Training Instructions are intended to provide general guidelines for the successful use of this curing equipment.

All personnel operating the machine must read and understand the safety and operating instructions before using the equipment. Regular equipment maintenance and performance awareness are essential to successful UV Coating applications.

PLANNING

Familiarize yourself with the unique requirements of each work area. This will ensure a safe and efficient coating application.

- Facility considerations including but not limited to:
 - Equipment access
 - Power availability; sufficient voltage and current
 - Supply Cord length requirements
 - Work permits and disposal restrictions
- Safety considerations including but not limited to:
 - Protective clothing, footwear and eyewear
 - Warning signs and cordoning off the work area
 - Environmental hazards such as the presence of flammable materials
- Environmental requirements such as humidity level
- Surface preparation requirements
- Consult your UV coating supplier for the correct application procedure for your coating type. Many coating manufacturers offer training courses for contractors. Be aware of the requirements for each coating:
 - Application method
 - Application thickness
 - Cure speed
 - Number of coats
 - Repair and refinishing
- Plan the curing route



RECEIVING THE CURING MACHINE

Always inspect the shipping crate and equipment for signs of damage. If serious damage is evident, document it and contact shipping company to file a claim.

UNPACKING THE CURING MACHINE

- Keep box and packaging materials.
- Follow the Moving Instructions located in the Safety section in this manual.
- Keep these Operating Instructions in the manual holder provided with the equipment.



BEFORE EACH USE

- Follow the maintenance instructions specified in this manual to ensure equipment is safe and clean.
- Check the Irradiator to make sure a UV Lamp is installed and is in good condition. If not, follow the removal and installation procedure in the How to Change a UV Lamp section in this manual.



BEFORE APPLYING COATING

- Check machine operation before applying coating.
 - Uncoil all power cables before use.
 - All persons in the work area must wear UV protective garments and Face Shields before starting the UV Lamp.
 - Start the machine
 - Check the UV Lamp reaches the desired power level when the Irradiator is removed from the Docking Station.
 - Switch equipment off before applying coating.
- Place UV warning signs prominently and cordon off work area. Ensure that all unprotected individuals, pets and other animals are outside the work area.

CURE HEIGHT

Unless otherwise directed by your coating supplier, the optimum Cure Height (distance above the coating) for JUVC-5B is 2 inches [50mm] - see Fig. 12. The UV light will have the greatest intensity at the focal point.

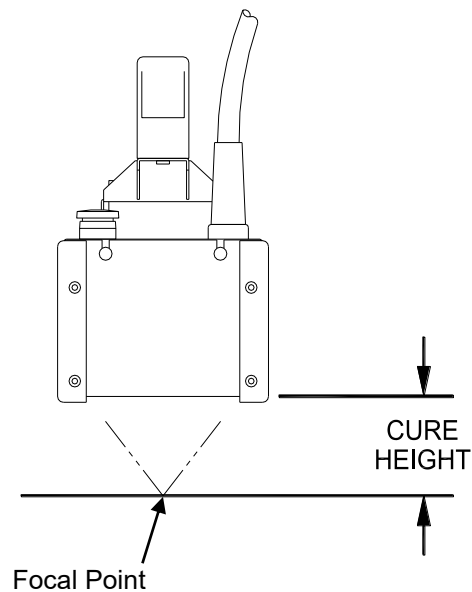

Fig. 12 Cure Height

CURE WIDTH

The JUVIC-5B has a 5 inch [125mm] Cure Width - see Fig. 13. The cure width may be wider, depending upon coating type and thickness.

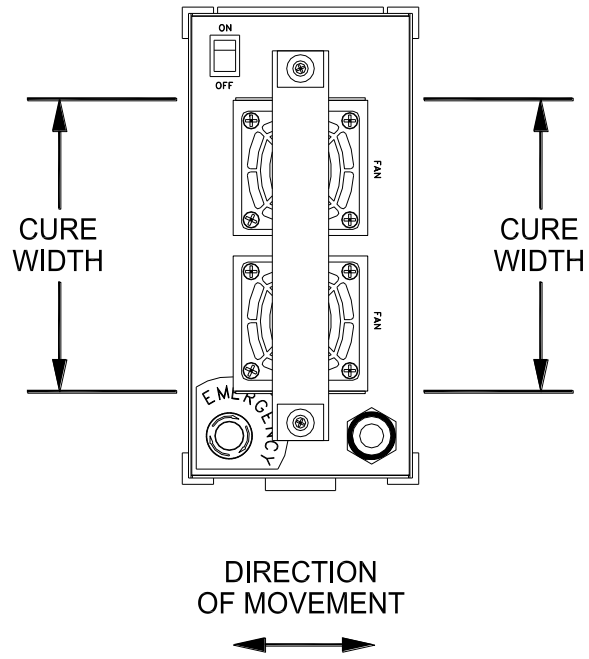

Fig. 13 Cure Width

CURE OVERLAP

Always overlap the cured area by approximately 1 inch [25mm] to ensure a consistent cure.

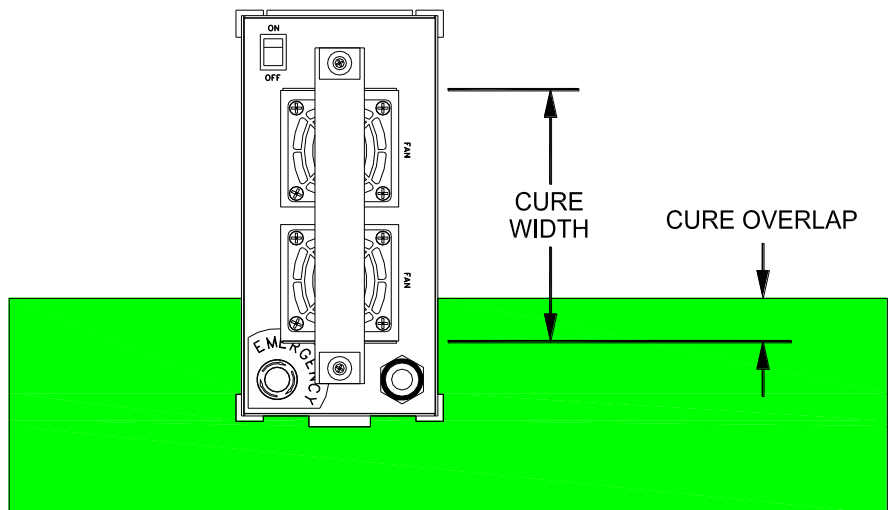
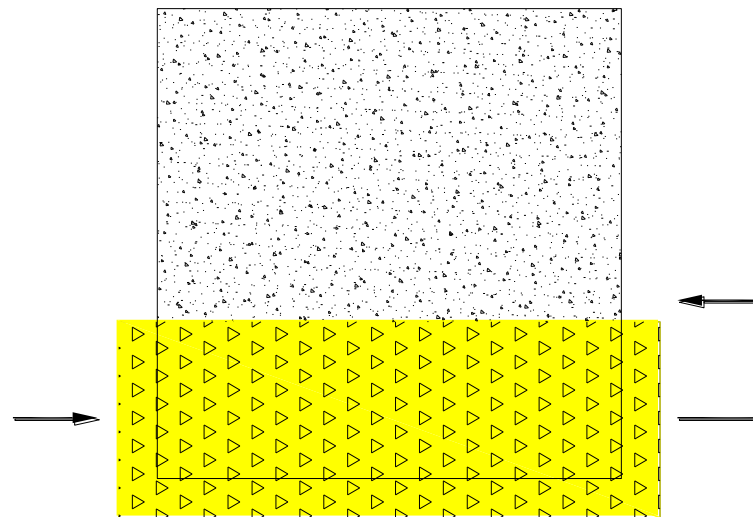

Fig. 14 Cure Overlap

CURING EXAMPLE

The following example shows the recommended method for curing a 12 inch [300mm] square tile. Unless otherwise directed by your coating supplier, move the Irradiator in a slow sweeping motion approximately 2 inches [50mm] above the coating. The speed of each pass should be determined by the heat sensitivity of the coating and substrate material. For non-heat sensitive materials, move a distance of 12 inches [300mm] every 5 seconds. For heat sensitive materials, increase the speed of each pass. Several passes may be required before the material is fully cured. Start curing along the closest edge, moving further away with each pass. Always overlap the cure area. Use caution, the Irradiator and work surface will become hot.

Step 1.



PLAN VIEW

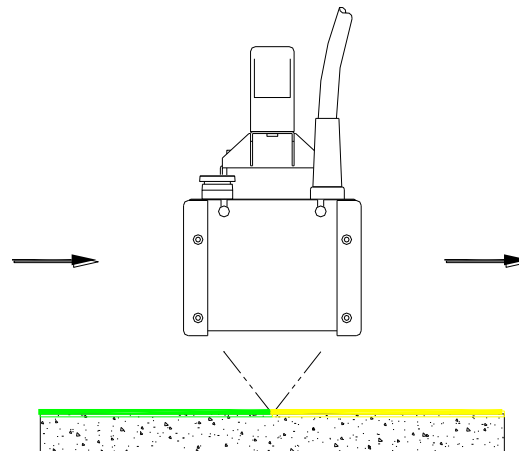

SIDE VIEW

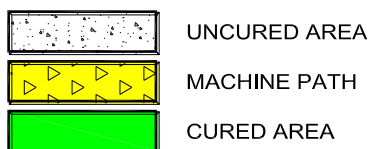

Step 2.

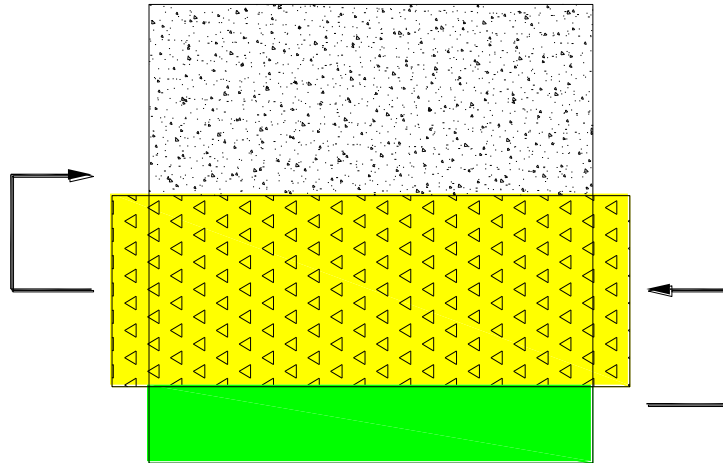

Step 3.

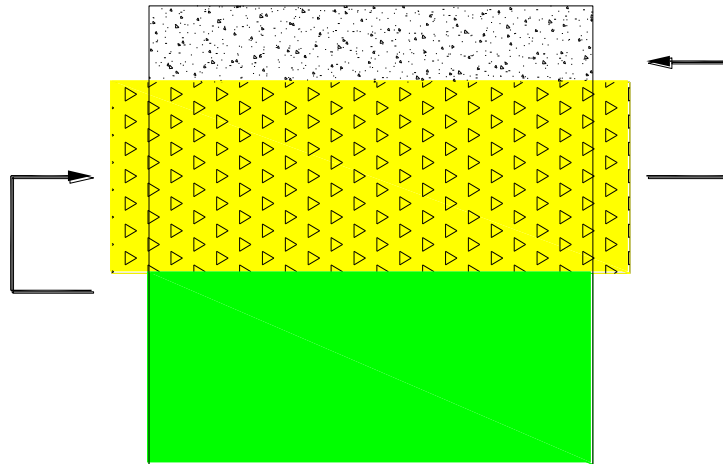

Step 4.

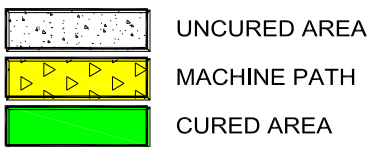
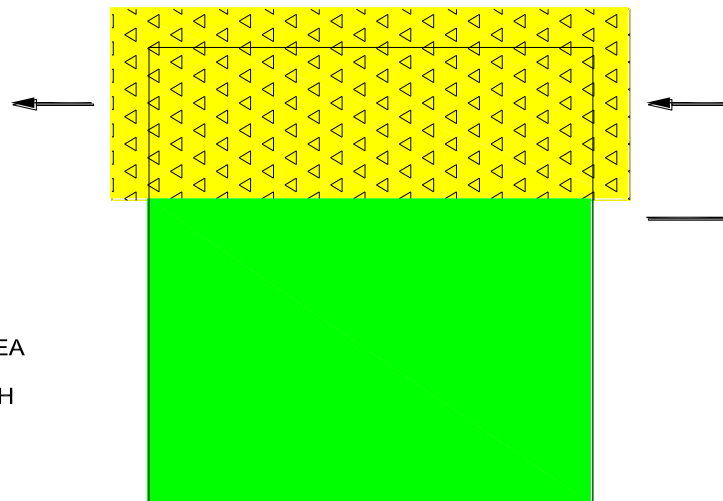

Step 5.

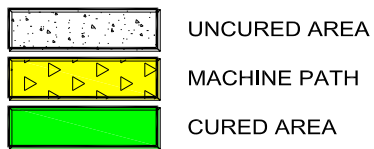
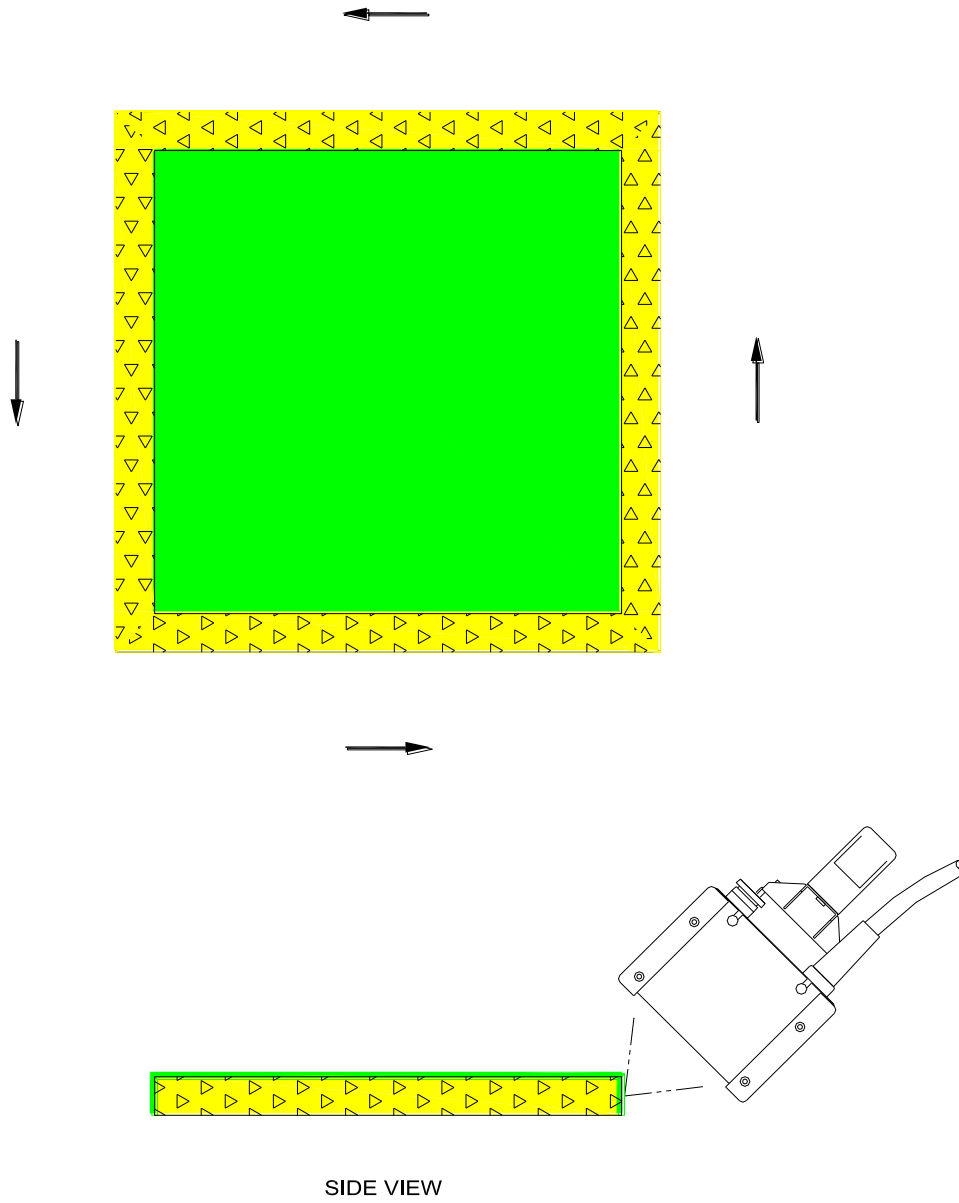

USER-MAINTENANCE INSTRUCTIONS

RECOMMENDED TOOLS AND SUPPLIES

- Screwdriver set comprising of Phillips and Flat Blade tips. The set must include:
 - Phillips screwdriver with tip size no. 2
- Inch size Hex L-Key (Allen Key) set: 5/64 thru 3/16 inch sizes. The set must include:
 - 7/64 AF (.109 inches across the flats)
- Deionized (DI) Water
- Clean-Up kit for a broken UV Lamp;
 - Paper Towels
 - Cotton Cloths
 - Newspaper
 - Heavy duty Rubber Gloves
 - Biohazard Bags at least 20 inches [600mm] high
 - Heavy duty Sticky Tape approximately 2 inches [50mm] wide
 - Dustpan (brush is not required)
 - Cardboard pieces approximately 6 inches [150mm] square

OPTIONAL TOOLS

- Pliers; Long Nose
- Multi-meter

RECOMMENDED SPARE PARTS

Contact your distributor or manufacturer for spare parts

- UV Lamp, P/N UVC1427
- Lamp Holder Assembly, P/N IRC60-0611 (qty 2)



WARNING! Hazardous Voltage;

This equipment and Supply Cord operate at high voltages and current. Electric shock from any of these components can cause serious injury or death.

- Always remove the plug on the Supply Cord from the socket-outlet before performing any maintenance.
- Never spray water or other cleaning liquids on the equipment.



WARNING! Hot Surface(s);

This machine will get hot in use and can cause severe damage to equipment and serious injury to persons. Always allow the machine to cool for 15 minutes after use before performing any maintenance.

TO CHANGE THE UV LAMP



WARNING! Hot Surface(s);
WARNING! Serious Injury May Result;
UV Lamp and housing may be hot.

- Allow the Irradiator Module, UV lamp and surrounding surfaces to cool for at least 15 minutes before handling.
- Wear protective gloves.
- A broken UV Lamp can cause injury and will be contaminated with mercury. In this instance, refer to Safety, What to do if a UV Lamp Breaks section in this manual.

To remove the UV Lamp

- Remove the two Irradiator Cover Screws at either end of the Irradiator Module using a Phillips screwdriver tip size no. 2
- Pull the Irradiator Removal Handles to remove the inner housing.
- Turn inner housing upside down.
- Loosen or remove the four Screws retaining the UV Lamp End Caps using a 7/64 inch Hex L-Key.
- Remove the UV Lamp with care.

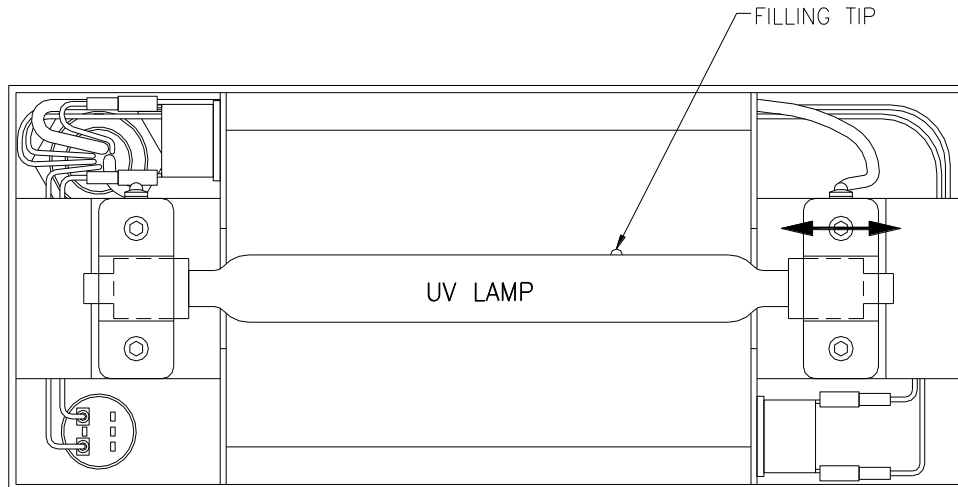

Fig. 16 Irradiator Underside View

Cleaning

- It is recommended to clean the reflector whenever the UV Lamp is changed. Use a paper towel moistened with Deionized (DI) Water.
- Do not touch a new UV Lamp with bare hands; this will reduce the lifespan of the UV Lamp. Always wear gloves. If a UV Lamp does require cleaning, use a paper towel moistened with Deionized (DI) Water.

UV Lamp installation (Opposite of Removal)

- Always use a manufacturer approved UV Lamp.
- If the UV Lamp has a Filling Tip (bump on the body) as shown in Fig. 16, position the Filling Tip towards the Irradiator Reflectors (upwards or sideways for general use).
- Align the End Clamp brackets with the center of each End Cap. The brackets securing the Lamp End Caps are designed to move as the lamp expands and contracts in use. Do not tighten the brackets in the outermost position.
- Gently tighten the screws holding the End Cap; over-tightening may damage the UV Lamp.



NOTE

MAINTENANCE SCHEDULE

This equipment requires periodic inspection and cleaning. The frequency of inspections should be increased if the equipment is operated or stored in environmental conditions beyond those recommended in this manual.

PREPARATION FOR EACH USE

- Check the Cooling Fan on top of the Irradiator is unobstructed and operational.
- Ensure all ventilation slots and holes are unobstructed. Clean with a vacuum cleaner; do not use compressed air.
- Inspect the condition of the UV Lamp and Reflectors. If the UV Lamp has blackened ends extending for more than 1/2 inch [12mm] replacement may be necessary. White marks on the UV Lamp are a normal consequence of aging. If cleaning is required use a Paper Towel moistened with Deionized (DI) Water. Never touch the UV Lamp with bare hands. If necessary, replace the UV Lamp in the Irradiator Module following the removal and installation procedure in the How to Change a UV Lamp section in this manual. UV Lamps should be replaced after 800 hours of use.

EVERY 3 MONTHS

- Inspect the condition of the Input and Output Cords for signs of damage, cracking and aging. If damage is found, replace the cord before further use. Do not attempt to repair a damaged cord. Contact your distributor or manufacturer for a replacement cord or repair.
- It may be necessary to clean the Input and Output Cords before use. Remove the plug from the socket-outlet. Use a moistened Cotton Cloth or Paper Towel to remove dust. Do not use chemical cleaning solutions. Use a separate cloth to dry. Allow the Supply Cord to dry thoroughly before reconnecting to equipment.
- It may be necessary to clean the equipment exterior. Remove the plug on the Supply Cord from the socket-outlet. Use a vacuum cleaner and moistened Paper Towel to remove dust. Do not use chemical cleaning solutions. Do not immerse equipment or allow water to puddle. Use a separate Paper Towel to dry. Allow equipment to dry thoroughly before reconnecting the Supply Cord.

TROUBLESHOOTING

Problem	Diagnosis/Remedies
Power On/Off Switch is On but Ventilation Fan is Off	<ul style="list-style-type: none"> • Ensure that the Input Cord is correctly inserted into a suitable socket-outlet. • Ensure the Circuit Breaker Toggle Actuator on the Power Supply Control Panel is in the uppermost position. • Check or reset the main Circuit Breaker for the socket-outlet.
Ventilation Fan is On but the white Power Indicator will not illuminate when the green Start Button is pressed	<ul style="list-style-type: none"> • Ensure that the Emergency Stop Button on the Irradiator is in the on position: twist clockwise and pull up. • Make sure the Power Supply Cover is installed correctly. Safety Interlock Switches inside the Power Supply will prevent use if not engaged.
The White Power Indicator is On but the UV Lamp does not light when the green Start Button is pressed	<ul style="list-style-type: none"> • If the system has been used within the last few minutes, The UV Lamp may be too hot to start. Allow the Irradiator to cool for 5 minutes and retry. • The UV Lamp may require replacement. Switch the machine off and unplug from the socket-outlet. Remove the Irradiator Cover and check the UV Lamp for damage.
UV Lamp switches off during use	<ul style="list-style-type: none"> • Check plug is correctly installed into a socket outlet. • If the white Power Indicator is off: <ul style="list-style-type: none"> ○ The Thermal Switch inside the Irradiator may be too hot. The Thermal Switch will automatically reset when the Irradiator cools down to a safe temperature. This reason for the shutdown is most likely due to insufficient cooling. Refer to the User Maintenance section in this manual. ○ Check the Emergency Stop Button was not activated accidentally. ○ Check the Circuit Breaker Toggle Actuator on the Power Supply Control Panel is in the uppermost position. ○ Check or reset the main Circuit Breaker for the socket-outlet. • If the white Power Indicator is on: <ul style="list-style-type: none"> ○ If the UV Lamp flickers before shut-down, this may indicate the UV Lamp requires replacement. • Unplug the machine from the socket-outlet and inspect all cords for damage.
UV Lamp does not cure properly	<ul style="list-style-type: none"> • Ensure cure speed and height are appropriate to the UV coating. Consult your coating supplier for application recommendations. • Check the coating use by date, make sure it has been mixed correctly and ensure the preparation and application parameters are correct, such as thickness, moisture level, acidity levels etc. • Check age of the UV Lamp. UV Lamps should be replaced after 800 hours of use. • Check condition of the UV Lamp. If the UV Lamp has blackened ends extending for more than 1/2 inch [12mm] replacement may be necessary. White marks on the UV Lamp are a normal consequence of aging.

Consult your equipment dealer for further assistance or replacement parts.

SPECIFICATIONS

Model	Input Voltage	Current	Frequency
JUVC-5B	120 VAC ~	15A	60Hz
	200-240 VAC ~	11A	50Hz
	200-240 VAC ~	11A	60Hz
	100 VAC ~	15A	50/60Hz
Parameter		Value	
Ambient Operating Temperature		40-115°F [5-46°C]	
Ambient Operating Humidity		20-90% (with no condensation)	
Ambient Storage Temperature		40-115°F [5-46°C]	
Ambient Storage Humidity		20-90% (with no condensation)	
Sound Pressure Level LPA		< 75dB(A)	
Minimum Dimensions (Length x Width x Height)		12.5 x 10 x 22.5 inches [320 x 250 x 570mm]	
Weight		40lbs [18kg]	

Specifications



Jelight Company, Inc.

2 Mason, Irvine CA 92618 USA

Tel: +1-949-380-8774

Fax: +1-949-768-9457

<http://www.jelight.com>

e-mail:sales@jelight.com

LIMITED WARRANTY

What does this warranty cover?

This warranty covers any defects in materials and workmanship to the original end-user purchaser of this product with the exceptions stated below, provided the Warranty Registration Form has been returned to Jelight Company, Inc.

What does this warranty not cover?

This warranty does not cover damage or loss of parts incurred in transit, by abuse, misuse or an act of God (such as a flood), modifications (such as the installation and use of non-approved UV Lamps or other components), damage incurred through contact with oils or chemicals other than those specified in this manual when used as directed, any component that has been subject to unusual physical or electrical stress and consumable items (such as fan filters and capacitors). Also, consequential and incidental damages are not recoverable under this warranty. This warranty is non-transferable.

What is the period of coverage?

This warranty covers non-consumable components for a period of 12 months following the date of purchase, with the following exception:

The UV Lamp is covered for 3 months or 500 hours of use, whichever comes first.

What will Jelight Company, Inc. do to correct problems?

We will inspect your product and contact you within three days of receipt to advise the results of our inspection. If the product qualifies for warranty repair, Jelight Company, Inc. will elect whether to provide replacement parts and labor free of charge or replace the unit. If the product does not qualify for warranty repair, Jelight Company, Inc. will provide an estimate of the parts, labor and shipping charges required to complete the repair and return the product. If you authorize repairs, Jelight Company, Inc. will fix the product and return it within 21 days.

How can you get warranty service?

Contact Jelight Company, Inc. at the telephone number above for technical support and provide contact details, product name, serial number and date of purchase. If field repair is not possible, a Return Material Authorization (RMA) Number will be issued. This RMA number must be indicated on all shipping labels, documentation and communications relating to this repair.

Send the product to: Jelight Company, Inc.
2 Mason, Irvine, CA 92618
U.S.A.

How will state law affect your customer's rights under the warranty?

This warranty gives you specific legal rights, and you may also have other rights which vary from state to state.

Record your product information

Please record the information below and retain this for warranty service.

Date of Purchase	
Model Name / Number	
Serial Number	

Disclaimer:

Jelight Company Inc. warrants only that a product will conform to its physical descriptions, makes no other warranties and expressly disclaims any implied warranty of fitness for a particular reason. It is the responsibility of the purchaser to determine the suitability of the product for any purpose. All information provided by Jelight Company, Inc. is in good faith and when offered by another manufacturer or source is done so in good faith. In the event a warranty is offered by another manufacturer of goods or services, such warranty will convey from that manufacturer.

Jelight Company Inc. reserves the right to modify or discontinue this product at any time. All texts, graphics and logos in this manual are for guidance purposes and may be changed without notice. Jelight Company Inc. reserves the right to amend all or some of these terms and conditions at any time. Jelight Company Inc. declines all liability in the matter, as well as all responsibility for the accuracy, timeliness and/or completeness of the information contained, and for any use made of the information provided. Jelight Company Inc. assumes no obligation to update the data provided or to correct any errors. No rights may be relied from the information provided. Jelight Company Inc. and/or its rightful claimants, retains all rights (including copyright, trade mark and patent rights) in the material presented in this manual. No form of license is granted to the information. In particular, reproduction or making the content of this manual available to others in any form is strictly prohibited without prior written permission from Jelight Company Inc. Any unauthorized reproduction of art work is subject to legal action; and is protected by Federal, State and Local law.

In no event shall Jelight Company Inc. be responsible for particular, minor or significant damage, directly or indirectly, whether the claim is in contract, negligence or otherwise (including but not limited to, any interruption of service, loss of business, anticipated profit, or other consequential damages arising out of the use or inability to use this product or from any defect or omission in the manual, or other related items). In no event shall the liability of Jelight Company, Inc. exceed the purchase price of the product. These terms and disclaimer shall be governed by and interpreted in accordance with the laws of the United States.

© Copyright 2010 Jelight Company, Inc.



Jelight Company, Inc.

2 Mason, Irvine CA 92618 USA

Tel: +1-949-380-8774

Fax: +1-949-768-9457

<http://www.jelight.com>

e-mail:sales@jelight.com

WARRANTY REGISTRATION FORM

Registration entitles you to product support and notification of product upgrades and enhancements. We do not sell your name to third party mailing list companies. Information you provide is for the exclusive use of **Jelight Company, Inc.**

Please complete and return this form by surface mail to Jelight Company Inc. Alternatively, you may e-mail this information to warranty@jelight.com

Name	
Title	
Company	
Telephone	
E-mail	
Street Address	
City	
State / Province	
Zip / Postal Code	
Country	
Date of Purchase	
Model Name / Number	
Serial Number	

THIS PAGE INTENTIONALLY LEFT BLANK

