



Jelight Company, Inc.

2 Mason, Irvine CA 92618 USA

Tel: +1-949-380-8774

Fax: +1-949-768-9457

<http://www.jelight.com>

e-mail: sales@jelight.com

UVO-CLEANER®

Model 256 Series

Instruction Manual



Original Instructions REV D

Table of Contents

Safety Guide	2
TÜV Rheinland® Approval	3
Introduction.....	4
Specifications.....	5
Part Description	6
Front Panel	6
Rear Panel	7
Parts Assembly	8
System Setup	9
Lamp Installation	10
Timer – Program and Operation.....	11
System Operation	13
Scheduled Maintenance.....	14
Intensity Measurement.....	15
Troubleshooting.....	16
Limited Warranty	17
Warranty Registration Form.....	19
Appendix 1: Timer Settings Chart.....	20

Safety Guide

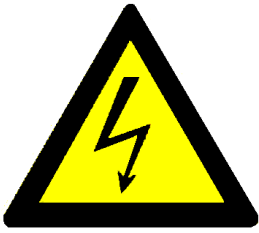

WARNING! Hazardous Voltage

Do not remove the cover while the equipment is plugged to an electrical outlet; risk of electric shock.



WARNING! Inhalation Hazard

Ozone is produced by this equipment during operation and appropriate ventilation must be provided for exhaust purposes. If ozone is detected in the area surrounding this equipment, immediately switch the machine off.



WARNING! Ultraviolet Light

The low-pressure mercury vapor grid lamp inside this equipment emits harmful UV radiation. Avoid exposure at all times! Protect eyes and skin.

This equipment should be operated by qualified personnel.

TÜV Rheinland® Approval

This UVO Cleaner is certified for cTÜVus Cert# CU 72080216 with UL fulfillment standards UL 61010-1:2004 & CAN/CSA-C22.2 61010-1:2004.



Also certified for EC conformity in accordance with EC Council Directive 2004/108/EC
Reg. # AE 720801320 0001



For more details, please log on to:
www.jelight.com/certifications.php#UVO
www.tuvdotcom.com

Introduction

UV+O (atomic oxygen) cleaning method is a photosensitized oxidation process in which the contaminant molecules of photo-resists, resins, human skin oils, cleaning solvent residues, silicone oils, and flux are excited and/or dissociated by the absorption of short-wavelength UV radiation. Atomic oxygen is simultaneously generated when molecular oxygen is dissociated by 184.9nm and ozone by 253.7nm.

253.7nm radiation is absorbed by most hydrocarbons and also by ozone. The products of this excitation of contaminant molecules react with atomic oxygen to form simpler, volatile molecules which desorb from the surface. Therefore, when both wavelengths are present, atomic oxygen is continuously generated, and ozone is continually formed and destroyed.

By placing properly pre-cleaned samples within five millimeters of ozone producing UV source, such as the low pressure mercury vapor grid lamp inside the UVO-Cleaner[®], near atomically clean surfaces can be achieved in less than one minute. In addition, this process does not damage any sensitive device structures of MOS gate oxide.

The UVO-Cleaner[®] is the safest and most effective method of removing organic contaminants from silicon, gallium arsenide, quartz, sapphire, glass, mica, ceramics, metals, and conductive polyimide cements. It is built to last with low maintenance and trouble free service.

Applications:

- Substrate cleaning prior to thin film deposition/descuming and stabilizing photo-resist
- Cleaning of silicon wafers, lenses, mirrors, solar panels, cold rolled steel, inertial guidance subcomponents, and GaAs wafers
- Cleaning of flux, hybrid circuits, and flat panel LCD
- Etching Teflon[®], Viton[®], and other organic materials
- Enhancing oxide passivated surfaces of GaAs and Si
- Reduce out-gassing of glass
- Wafer tape removal
- Improve adhesion of coatings on plastics
- Ink removal from wafers after testing
- Stripping photo-resist
- Removing latent images from lithography plates
- Cleaning lithography plates
- Growing oxide layers on silicon wafers
- Cleaning circuit boards prior to packaging/adhesion
- Increase hydrophilic characteristics of surfaces
- Cleaning and sterilization for bioscience applications
- Cleaning electronic microscope probes/slides or optical fibers/lenses
- Details of each application's data/journal/article: www.jelight.com/applications.php

Specifications

Outer Dimensions

Length	Width	Height	Exhaust Port (2x)	Media Inlet Port (4x)
32.00" [812.8 mm]	20.25" [514.4 mm]	12.00" [304.8 mm]	Ø 2.0" [50.8 mm]	Ø 0.375" [9.5 mm]

Tray Dimensions

Width	Length	Height (Adjustment Range)
16.00" [406.4 mm]	16.00" [406.4 mm]	0.25" ~ 3.00" [6 mm ~ 76 mm]

Grid Lamp

Type	Average Intensity	Distance Measured Away From Lamp
Low Pressure Mercury (Hg) Vapor	28 ~ 32 mW/cm ² @ 253.7 nm	.12" ~ .20" [3 ~ 5 mm]

Electrical Characteristics

Output Power

Voltage	Current
7500 V _{peak-peak}	65 mA

Available Input Power Requirements

Model	Voltage	Frequency	Current
256	120 V _{AC}	60 Hz	10.0 A
256-220	220 V _{AC}	50 Hz	6.0 A
256-220-60	220 V _{AC}	60 Hz	6.0 A
256-100	100 V _{AC}	50/60 Hz	12.0 A

Part Description

Front Panel

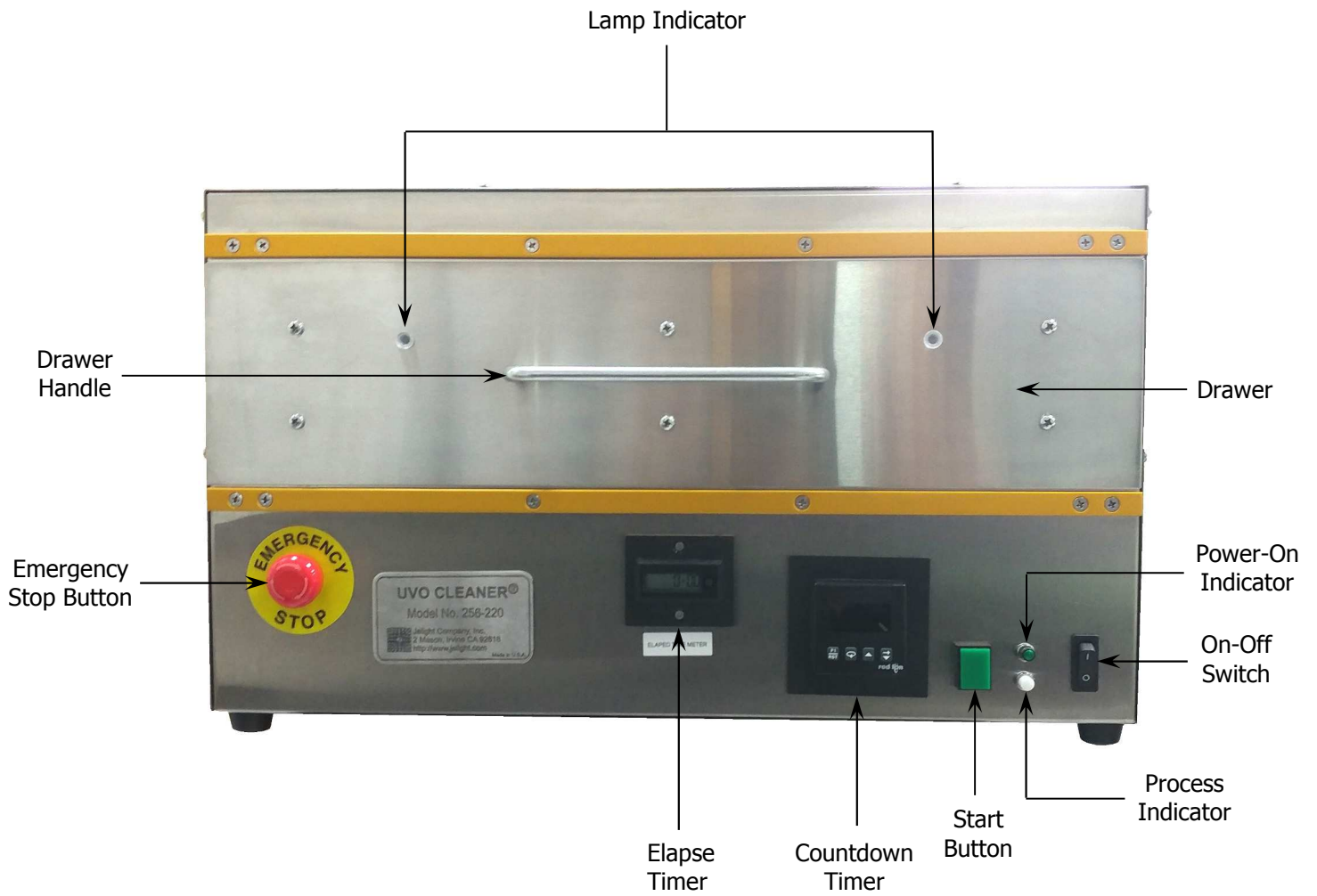

FIG. 1

Part Description (Continued)

Rear Panel

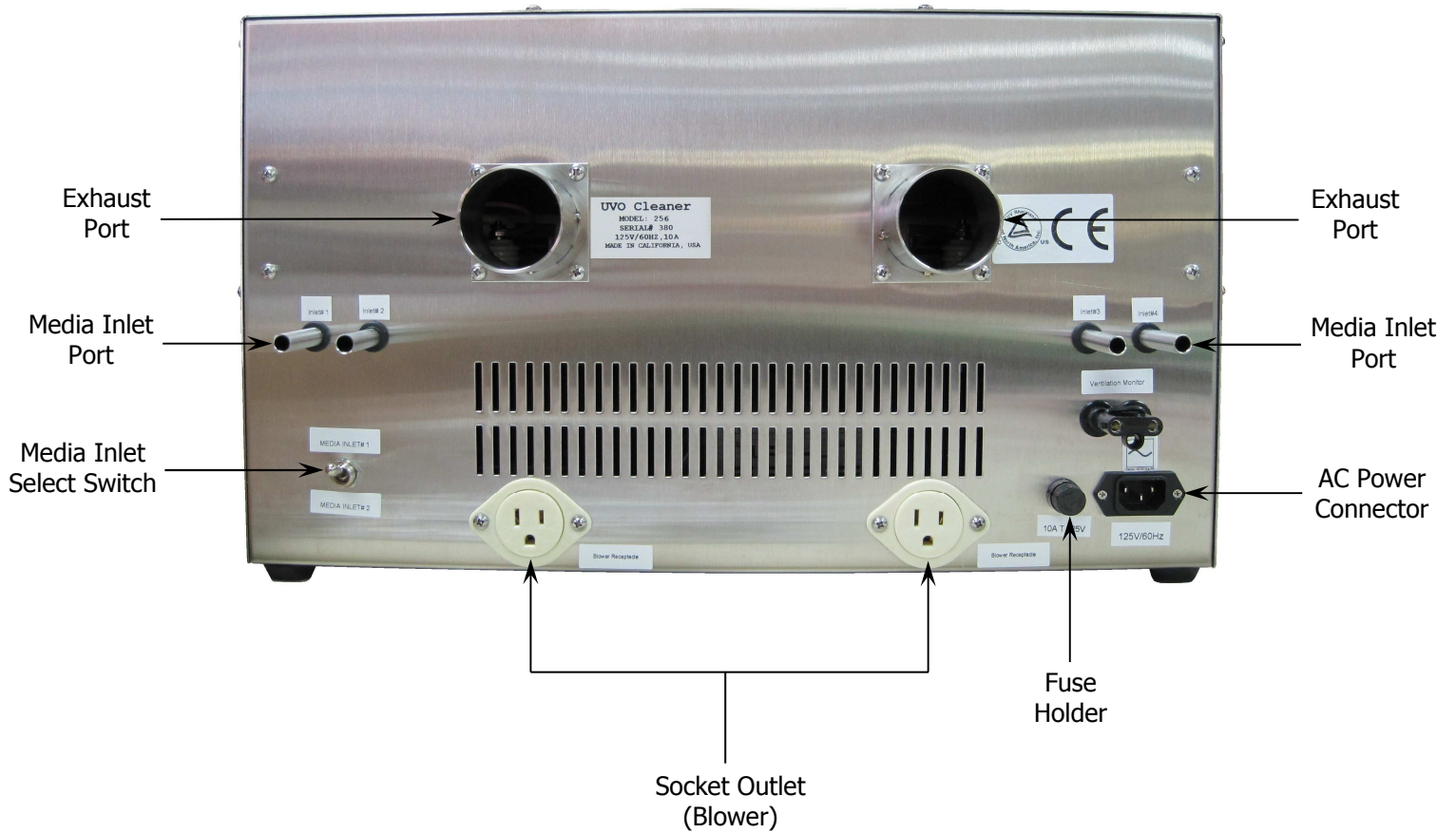

FIG. 2

Parts Assembly

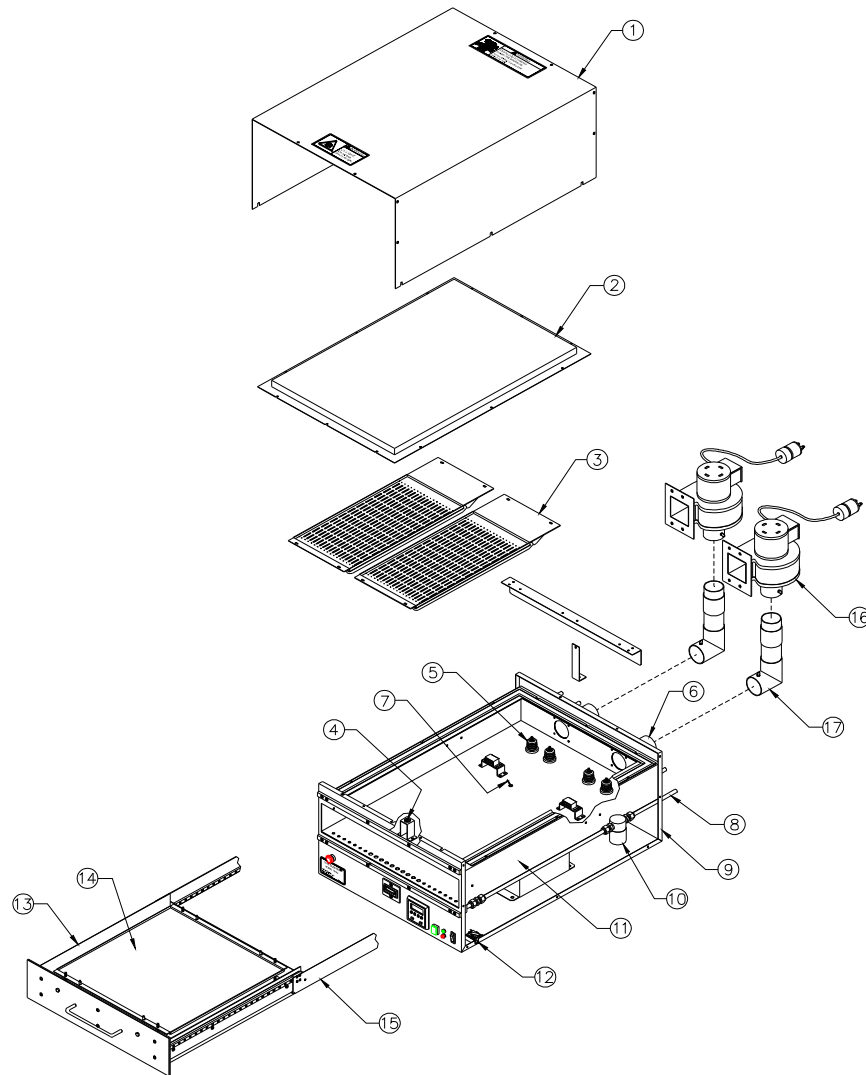

FIG. 3

- | | | |
|-----------------------------|--------------------------|---|
| ① Case Cover | ⑧ Media Inlet Port (4x) | ⑮ Slide Assembly (2x) |
| ② Lamp Cover | ⑨ Base | ⑯ Blower Assembly
(Optional Equipment) |
| ③ Lamp Assembly | ⑩ Valve (4x) | ⑰ Ozone Killer
(Optional Equipment) |
| ④ Elapse Timer/Reset Switch | ⑪ Support Shelf | |
| ⑤ Ceramic Feed-Through | ⑫ Cover Interlock Switch | |
| ⑥ Exhaust Port | ⑬ Drawer | |
| ⑦ Drawer Interlock Switch | ⑭ Cleaning Tray | |

System Setup

Refer To Figure 2 & 3

- 1 Connect Exhaust Port ⑥ to a suitable exhaust system capable of maintaining negative 0.1 to negative 0.5 inches [2.5mm-12.7mm] of static water pressure while in operation. A 2-inch [50.8mm] diameter flexible metal duct or PVC pipe may be used to attach this unit to the exhaust system.
The flow rate of the media should be equal to or less than that of the exhaust in order to maintain a positive flow of the media through the system. Using a greater flow rate of the input media will cause a backpressure in the system forcing the exhaust gases to leak into the operating environment.
Alternatively, install optional Blower Assembly ⑩ and Ozone Killer ⑪ onto Exhaust Port ⑥ and install the Blower plug into the Socket Outlet (Blower) at the rear of the machine.
- 2 Optional: The Ventilation Monitor in Figure 2 may be connected to a customer supplied flow meter measuring the exhaust system
- 3 Remove the vinyl caps from the Media Inlet Ports ⑧ located at the rear of the system.
- 4 Optional: Connect the Media Inlet Ports ⑧ to a media supply.
- 5 Install Lamp Assembly ③ per Lamp Installation Procedure.
- 6 Connect the Main power cord into the AC Power Connector at the rear of the UVO Cleaner® and to a socket outlet.
- 7 Switch the ON/OFF button to ON; the green power on indicator will illuminate.
- 8 Program the Countdown Timer as detailed in this instruction manual.

Lamp Installation

Refer To Figure 3

Procedures:

- 1 Remove the Case Cover ① .
- 2 Remove Lamp Cover ② .
- 3 Carefully place the Lamp Assembly ③ on top of the Support Shelf ⑪ with lamp side facing down.
- 4 Connect each lamp wire to a Ceramic Feed-Through ⑤ . The terminals must not come in to contact with enclosure.
- 5 Position the Lamp Cover ② on top of Lamp Assembly ③ . Use the #8-32 screws provided to screw both the Lamp Cover ② and Lamp Assembly ③ to the Support Shelf ⑪ .
- 6 Confirm Drawer Interlock Switch ⑦ is activated when Drawer ⑬ is fully closed.
- 7 If the UVO Cleaner® is equipped with an Elapse Timer, press the button on Reset Switch ④.
- 8 Place the Case Cover ① onto the system and secure with #8-32 screws.

Timer – Program and Operation

Refer to Figure 4. Model 624 utilizes a dual mode timer with two time presets:

- **Preset 1** specifies the total time for the cleaning and exhaust processes combined. This preset is locked from view and is only accessible from the Program menu. It should not be necessary to change the value. The Preset 1 value automatically adjusts to changes made to Preset 2 and is configured to provide a 2 minute exhaust cycle after the cleaning time has completed. The Preset 1 value must always be higher than Preset 2.
- **Preset 2** controls cleaning time. This preset can be changed by the operator.

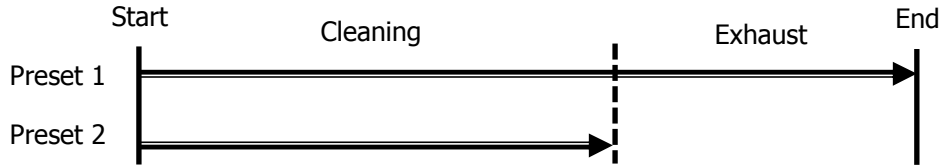

FIG. 4

Refer to Figure 5. The timer display indicates two time values and has two annunciator displays:

- The main display in red shows the time status for Preset 1. At power-up, the default value is 0.00 (0 minutes, 0 seconds). In operation, the timer will count upward until the Preset 1 time (cleaning and exhaust) is reached. At this point, the program will end and the timer will reset to 0.00.
- The secondary display in green is configured to indicate Preset 2 cleaning time. The factory default value is 5.00 (5 minutes, 0 seconds).
- The Preset Annunciator shown in green indicates which value is being viewed or modified.
- Output Annunciators will be visible at certain stages in the program.



FIG. 5







Button Function	Designation	Operation
Function 1 or Reset Key	F1 RST	The Function 1 option is not enabled. Press to reset the time value in Preset 1. In normal use, operation of this button is not necessary. Press this button to recover the UVO Cleaner® from an Emergency Stop event or power outage during operation.
Access/Enter Key		Press once to display the set value for Preset 2. After the Preset has been changed, press this button again to store the value. Press and hold for 2 seconds to enter Program menu. Press repeatedly to sequence through menu options. After the Program menu has been changed, press this button again for 2 seconds to store the value and return to the main screen.
Value Increase Key		In the Preset or Program screens, press this button to increase the time value or advance to the next parameter.
Value Decrease/Next Key		In the Preset screen, press this button to decrease the time value. In the Program screens, press this button to reduce values or select the previous parameter.

FIG. 6

Changing Timer Preset Values

Note: Do NOT adjust timer programs while using this equipment for process.

To Change Preset 2 Cleaning Time:

- Press the  button once to enter the Preset change screen.
- Adjust the Preset 2 time using the  and  buttons.
- Press the  button once to return to the main screen. The new preset time should be visible.

Refer to Appendix 1 at the rear of this manual for the complete listing of Timer Program settings.

System Operation

WARNING:

- Follow all instructions in System Setup before applying power to the UVO Cleaner®.
- In case of emergency, push the emergency stop button on the front panel and unplug the machine. Do not open the drawer. To restart, twist the emergency button clockwise to reset. Allow the blower to operate for 5 minutes before opening the drawer.

- 1 Connect the Main power cord into the AC Power Connector at the rear of the UVO Cleaner® and to a socket outlet.
- 2 Switch the ON/OFF button to ON; the green power ON indicator will illuminate.
- 3 Load the substrate on the removable Cleaning Tray. Substrates should be pre-cleaned before processing in the UVO Cleaner®. Removing large amounts of contamination will take long periods of time. Normal cleaning time should be determined through experimentation.
- 4 Adjust the feet on the tray to set the desired height. The actual height of the tray will vary according to the height of the substrate. For optimum results, the surface of the substrate should be situated approximately 0.20" [5 mm] below the grid lamp.
- 5 Once the Drawer is closed completely, the Drawer Interlock Switch will engage. If either the Drawer or the Case Cover is removed, the Drawer Interlock mechanism will automatically turn OFF the lamp. This feature prevents operator exposure to harmful UV radiation.
- 6 Program the timer as desired. Press the start button to begin the cleaning process. The red Process Indicator will illuminate.
- 7 When the cleaning and exhaust cycles are complete, the Timer will sound an audible signal and the red Process Indicator will turn off. Do not open the drawer before the exhaust cycle is complete.
- 8 The Elapse Timer displays the number of hours the UV Lamp has been in service and should be reset every time the UV Lamp is replaced. To reset the Elapse Timer, refer to Lamp Installation Procedure.

Scheduled Maintenance

WARNING:

- This equipment should be serviced by qualified personnel.
- Lamps are fragile, handle with care.
- Before performing maintenance, the power cord must be unplugged from system.
- The low pressure mercury vapor grid lamp inside this equipment emits harmful UV radiation; avoid exposure at all times. Protect eyes and skin.

UVO-Cleaner® requires minimal maintenance. After every 100 hours of operation, remove the lamp assembly and eliminate particles by applying deionized water, then dry with a clean cloth. Check the intensity of the lamp by using a radiometer and detector. The lamp assembly should be replaced when the intensity is measured at or less than 21 mW/cm² @ 254 nm, with a measuring distance of .12" - .20" [3 - 5 mm] between the lamp and the detector.

The lamp assembly should be replaced after 5,000 to 10,000 hours of operation (for detailed instructions on lamp installation, please refer to page 9).

Please contact Jelight Company Inc. for pricing and availability of replacement UV lamps, radiometer, detectors, and other components.

Intensity Measurement

Procedure:

- 1 Allow current cleaning cycle to complete and wait a minimum of 5 minutes for ozone to be removed from the UVO-Cleaner[®] before proceeding.
- 2 Turn ON the UVO-Cleaner[®] and set the cleaning time to 15 minutes.
- 3 After 5 minutes, press the STOP button and open the Drawer.
- 4 Open the Drawer and place the Detector in the center of the Cleaning Tray. Set the distance between the top of Detector **C** and the Lamp Assembly **A** to approximately .12 - .20" [3 - 5mm]. Adjust the height of Cleaning Tray by turning the thumb nut on 4 sides.
- 5 Position the Detector wire against the rubber surrounding the Drawer face plate and carefully close the Drawer (see illustration below). The rubber will compress to allow the Drawer to fully close and engage the Drawer Interlock Switch.
- 6 Turn ON the Radiometer.
- 7 Press the START/RESUME button to continue the UVO cleaning cycle.
- 8 At this time, the intensity reading should continuously increase; wait 5 minutes for the reading to stabilize. Record this measurement.
- 9 Press the STOP button but continue blower operation for an additional 5 minutes to eliminate excessive ozone before opening the Drawer.
- 10 Open the Drawer and remove the Detector.
- 11 The UVO-Cleaner[®] may now be turned off.

Illustration

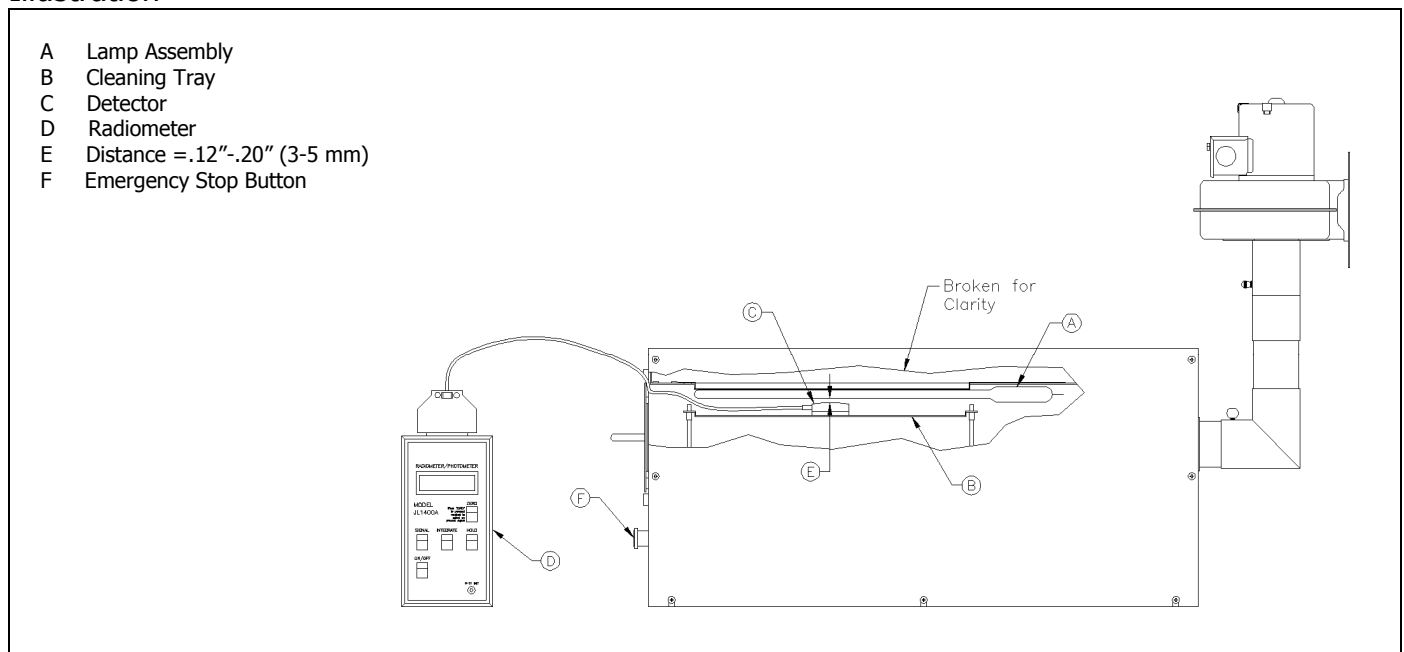

Troubleshooting

Problems:	Suggestions:
The system has no power.	<ul style="list-style-type: none"> • Twist the Emergency Stop Button clockwise and pull outward to reset. • Check the Power Cord is undamaged and plugged into the AC Power Connector at the rear of the machine and to a Socket Outlet. • Check the Fuse on the rear panel. • Check the Cover Interlock Switch to make sure it is totally engaged. • Check or reset the main Circuit Breaker for the Socket Outlet.
The system has power but the Timer does not operate.	<ul style="list-style-type: none"> • Check the Drawer is closed properly. The Drawer Interlock Switch behind the Drawer should make an audible click sound when the Drawer is fully closed.
Lamp Indicator (on the drawer) does not light up.	<ul style="list-style-type: none"> • Ensure the Process Indicator lamp is on. • Check the UV Lamp Assembly for breaks, cracks, or other kind of damage.
Ozone is present outside of the system during operation.	<ul style="list-style-type: none"> • Ensure the Exhaust connections are tight. • Make certain that the Ozone Killer & Blower assembly are connected in the upright position, as shown on page 8. • Check the Drawer is closed properly. The Drawer Interlock Switch behind the Drawer should make an audible click sound when the Drawer is fully closed. • Check the rubber seal around the drawer edge.
The intensity measurement is below normal.	<ul style="list-style-type: none"> • Replace UV Lamp Assembly. • If the system has not been used for several hours, the UV lamp may be cold and should be allowed to warm up for 5 minutes. • If the system has been used extensively for long periods of time, the UV lamp may be too hot. Allow the lamp to cool with the drawer open for 1 hour. • Distance between the lamp and detector should be no more than .12"-.20" [3 - 5 mm]. • Radiometer/detector may require recalibration. Recommended calibration period is 3 – 4 months when subjected to strong UV radiation. The photodiode located inside the detector will eventually become solarized. If solarization occurs, the detector will require replacement.

* For further assistance, contact Jelight Company Inc. 2 Mason, Irvine CA 92618 U.S.A.
+1(949) 380-8774



Jelight Company, Inc.

2 Mason, Irvine CA 92618 USA

Tel: +1-949-380-8774

Fax: +1-949-768-9457

<http://www.jelight.com>

e-mail: sales@jelight.com

Limited Warranty

What does this warranty cover?

This warranty covers any defects in materials and workmanship to the original end-user purchaser of this product with the exceptions stated below, provided the Warranty Registration Form has been returned to Jelight Company, Inc.

What does this warranty not cover?

This warranty does not cover damage or loss of parts incurred in transit, by abuse, misuse or an act of God (such as a flood), modifications (such as the installation and use of non-approved UV Lamps or other components), damage incurred through contact with oils or chemicals other than those specified in this manual when used as directed, any component that has been subject to unusual physical or electrical stress and consumable items (such as fan filters and capacitors). Also, consequential and incidental damages are not recoverable under this warranty. This warranty is non-transferable.

What is the period of coverage?

This warranty covers non-consumable components for a period of 12 months following the date of purchase, with the following exception: the UV Grid Lamp is not covered within this warranty.

What will Jelight Company, Inc. do to correct problems?

We will inspect your product and contact you within three days of receipt to advise the results of our inspection. If the product qualifies for warranty repair, Jelight Company, Inc. will elect whether to provide replacement parts and labor free of charge or replace the unit. If the product does not qualify for warranty repair, Jelight Company, Inc. will provide an estimate of the parts, labor and shipping charges required to complete the repair and return the product. If you authorize repairs, Jelight Company, Inc. will fix the product and return it within 21 days.

How can you get warranty service?

Contact Jelight Company, Inc. at the telephone number above for technical support and provide contact details, product name, serial number and date of purchase. If field repair is not possible, a Return Material Authorization (RMA) Number will be issued. This RMA number must be indicated on all shipping labels, documentation and communications relating to this repair.

Send the product to: Jelight Company, Inc.

2 Mason

Irvine, CA 92618

How will state law affect your customer's rights under the warranty?

This warranty gives you specific legal rights, and you may also have other rights which vary from state to state.

Record your product information

Please record the information below and retain this for warranty service.

Date of Purchase	
Model	
Serial Number	

Disclaimer:

Jelight Company Inc. warrants only that a product will conform to its physical descriptions, makes no other warranties and expressly disclaims any implied warranty of fitness for a particular reason. It is the responsibility of the purchaser to determine the suitability of the product for any purpose. All information provided by Jelight Company, Inc. is in good faith and when offered by another manufacturer or source is done so in good faith. In the event a warranty is offered by another manufacturer of goods or services, such warranty will convey from that manufacturer.

Jelight Company Inc. reserves the right to modify or discontinue this product at any time. All texts, graphics and logos in this manual are for guidance purposes and may be changed without notice. Jelight Company Inc. reserves the right to amend all or some of these terms and conditions at any time. Jelight Company Inc. declines all liability in the matter, as well as all responsibility for the accuracy, timeliness and/or completeness of the information contained, and for any use made of the information provided. Jelight Company Inc. assumes no obligation to update the data provided or to correct any errors. No rights may be relied from the information provided. Jelight Company Inc. and/or its rightful claimants, retains all rights (including copyright, trade mark and patent rights) in the material presented in this manual. No form of license is granted to the information. In particular, reproduction or making the content of this manual available to others in any form is strictly prohibited without prior written permission from Jelight Company Inc. Any unauthorized reproduction of art work is subject to legal action; and is protected by Federal, State and Local law.

In no event shall Jelight Company Inc. be responsible for particular, minor or significant damage, directly or indirectly, whether the claim is in contract, negligence or otherwise (including but not limited to, any interruption of service, loss of business, anticipated profit, or other consequential damages arising out of the use or inability to use this product or from any defect or omission in the manual, or other related items). In no event shall the liability of Jelight Company, Inc. exceed the purchase price of the product. These terms and disclaimer shall be governed by and interpreted in accordance with the laws of the United States.

*UVO-Cleaner® is a registered trademark of Jelight Company, Inc.

© Copyright 2010 Jelight Company, Inc. 2 Mason Irvine, CA 92618 USA



Jelight Company, Inc.

2 Mason, Irvine CA 92618 USA

Tel: +1-949-380-8774

Fax: +1-949-768-9457

<http://www.jelight.com>

e-mail: sales@jelight.com

Warranty Registration Form

Registration entitles you to product support and notification of product upgrades and enhancements. We do not sell your name to third party mailing list companies. Information you provide is for the exclusive use of Jelight Company, Inc.

Please complete and return this form by surface mail to Jelight Company Inc. Alternatively, you may e-mail this information to: warranty@jelight.com

Name	
Title	
Company	
Telephone	
E-mail	
Street Address	
City	
State / Province	
Zip / Postal Code	
Country	
Date of Purchase	
Model	
Serial Number	



Appendix 1: Timer Settings Chart

To restore the UVO Cleaner® Timer to factory program configuration, enter the following settings:

Function

Timer Display	Program Parameter	Value
EnrY	Numeric Value Entry Method	AutoSc
trAnGE	Timer Range	n.SEC
OPeR	Timer Operating Mode	1
rSt.P.uP	Timer Reset At Power-Up	no

Presets

Timer Display	Program Parameter	Value	
		Preset 2	Preset 1
Ac PrS	Access Preset Values	-y	-L
PrESEt	Preset 1 Value	7.00	
PrESEt	Preset 2 Value	5.00	
P1trAc	P1 Track P2	yes	

Outputs

Timer Display	Program Parameter	Value	
		Preset 2	Preset 1
Ac Out	Access Output Time Values	-L	-L
OutrES	Output Resolution	0.1SEC	
OutPut	Output 1 Time	0.10	
OutPut	Output 2 Time	0.10	
rEVOuT	Reverse Relay/Output Logic	-y	-y
rEVAnu	Reverse Annunciator Logic	-y	-y
OutP.uP	Output Power-Up State	-O	-O

User Inputs

Timer Display	Program Parameter	Value
USrIn1	User Input 1	rSt. -L
USrIn2	User Input 2	rSt. -L
USrIn3	User Input 3	rSt. -L
USr F1	User F1 Key	rSt. -L
CodE	Programming Code Value	0
ScroLL	Scroll Display	no